



Workplace Health *and* Safety

Training Resource Kit

Workplace Health and Safety Training

Preface	2
Introduction	3
Pre-evaluation	15
Topic 1 The safety law	19
Topic 2 Health and hygiene	38
Topic 3 Recognising safety hazards	48
Topic 4 Manual handling	63
Topic 5 Hazardous substances	81
Topic 6 Noise in the workplace	97
Topic 7 Machine and equipment safety	113
Topic 8 Personal protective equipment	127
Topic 9 Working in confined spaces	138
Topic 10 Emergency procedures	147
Topic 11 Claims management and rehabilitation	165
Topic 12 Workplace bullying and harassment	177
Review	197



Reprinted 2002

© 1998 Commonwealth of Australia. Funded under the Workplace English Language and Literacy (WELL) Programme by the Commonwealth through the Department of Education Science and Training (DEST), formerly DETYA. This work is copyright. It may be reproduced subject to the inclusion of an acknowledgement of the source WorkCover Corporation SA and Workplace Education Services TAFE SA.

Preface

This section is not a step-by-step user's manual. Rather, it has been included to provide some background information to the development of the Resource Kit itself. It was felt important that the design principles needed to be elaborated upon in some details so that skilled facilitators could see the scope of the resources and their potential application with a diversity of learner needs.

Acknowledgements

This Kit has been developed by a Project Team consisting of lecturers from the Workplace Education Service (WES) of Adelaide Institute of TAFE and WorkCover Corporation Access and Equity Program consultants. The core team consisted of Carolyn Dillon (Project Co-ordinator), Fiona Gilmore from the Adelaide Institute, and Italia Mignone and Dianna Tramsak, WorkCover Corporation SA.

The Project Team acknowledges the many people who took the time to review drafts and assist with the design and development of this Training Resource Kit, in particular, WorkCover Corporation occupational health and safety trainers and consultants, the Employee Relations Team at Bridgestone TG Australia Pty Ltd and the trainees involved in the trialing phase for their insightful feedback. We would also like to thank all the people who provided the administrative support to type the original kit used for the pilot trial.

Written by: Carolyn Dillon, Fiona Gilmore, Italia Mignone and Dianna Tramsak
Produced by: WorkCover Corporation of South Australia.



Reprinted 2002

© 1998 Commonwealth of Australia. Funded under the Workplace English Language and Literacy (WELL) Programme by the Commonwealth through the Department of Education Science and Training (DEST), formerly DETYA. This work is copyright. It may be reproduced subject to the inclusion of an acknowledgement of the source WorkCover Corporation SA and Workplace Education Services TAFE SA.

Introduction

In South Australia, the Occupational Health, Safety and Welfare Act, 1986, establishes the overall requirements for protecting health and safety in the workplace. WorkCover Corporation has an ongoing commitment to assist and support employers and workers to work together to develop skills and put systems in place to maximise health and safety in the workplace.

For some years there has been an identified shortage of up-to-date resources for workplace trainers and consultants working with learners with limited language or literacy skills. Available resources either have been out-of-date in terms of legislative changes, or inappropriate in their assumption of language and literacy competencies, particularly in the manufacturing sector.

In the past decade, there has been a significant move toward the integration of language, literacy and numeracy competencies with vocational competencies. Occupational Health, Safety and Welfare (OHS&W) is of particular importance as it is a requirement of all workforce employees irrespective of their underpinning communication skills.

This Resource Kit has been designed with two critical factors in mind; firstly, the competencies required by employees who are under direct supervision in the workplace; and secondly, employees who are in need of language and literacy skills development. This Resource Kit seeks to integrate these competencies and build learning from both perspectives simultaneously.

It is hoped that this innovative, plain language kit will fulfil the demand for up-to-date resources that address both the legislative requirements and the literacy needs of learners in the workplace. Whilst this resource kit has been developed in South Australia, the Occupational Health, Safety and Welfare competencies that it addresses have been drawn from the National Guidelines for Integrating Occupational Health and Safety Competencies into National Industry Competency Standards [NOHSC: 7025 (1994)].

Background

WorkCover Corporation's Access and Equity Unit, working with lecturers from the Workplace Education Service, Adelaide Institute of TAFE, identified that occupational health and safety training in SA workplaces was not effectively addressing the needs of workers with limited English language and literacy skills. It was important to develop a resource that could be used in workplace training to teach occupational health and safety competencies while taking into account the language and literacy needs of workers.

The Department of Employment, Education and Training and Youth Affairs (DEETYA) funded the development and trialing of this Resource Kit through a Workplace English, Language and Literacy (WELL) grant. There were two purposes; firstly, the development of resources that could be used nationally; and secondly, for the delivery of training to a specific group of learners at Bridgestone TG.

Bridgestone TG Australia Pty Ltd is an automotive components manufacturer situated in Adelaide. They had a requirement to train all of their workforce in the principles of occupational health, safety and welfare. However, with a workforce consisting of 65% non-English-speaking-background (NESB) employees, there was a need to develop resources that would meet the diverse needs of the workers as well as satisfy the requirements of the OHS&W legislation.

The Resource Kit was developed by the project team and the occupational health and safety content was reviewed by WorkCover Corporation's trainers and consultants.

The resources were subsequently trialed at Bridgestone TG by the Workplace Education Service with the support of WELL funding. Feedback from this training was used to modify the Resource Kit.

Competency-based assessment

The training resource materials developed for this project are based on the accredited curriculum module, OHS&W Generic Fundamentals A, which is in turn based upon the national safety competency standards for employees. It is important to note these materials do not exist in isolation but are linked into a systems approach to the management of OHS&W in the workplace.

The overall approach to the systematic management of OHS&W in the workplace requires the involvement of managers to establish an appropriate system, supervisors to implement the system, and employees to contribute to the system. This Resource Kit has been developed to assist employees, particularly those with limited English language and literacy skills, to contribute to participative arrangements for the management of OHS&W in the workplace. Appropriate evaluation, review and adjustment of the overall OHS&W system within an organisation still remains the responsibility of management.

The table on page seven, outlines the relationship between the National Occupational Health and Safety competency standards, Generic Fundamentals A, the relevant topics in the Training Resource Kit, and employee learning outcomes.

The Project Team also endeavoured to build in opportunities for trainers to develop the key competencies as the training progressed. The relevant key competencies addressed by these resources are:

- collecting, analysing and organising information
- communicating ideas and information
- working with others and in teams
- solving problems.

There is sufficient opportunity within the Resource Kit, through a combination of learning activities, to determine the competence of an individual learner in an off-the-job setting. However, if competency standards are to be a reflection of required standards in the workplace, then there is a need to develop on-the-job assessments that look at the occupational health and safety competencies in a specific context. The overriding purpose of competency-based training is to ensure that change occurs within the workplace environment. Each workplace needs to integrate this training into their performance management and/or assessment systems as they see fit.

National OH&S competencies matched to learning outcomes

National guidelines for integrating occupational health and safety competencies into national industry competency standards NOHSC:7025(1994) Generic Competency A relevant for employees without supervisory responsibilities		Workplace Health and Safety Training Resource Kit	Competency demonstrated
Elements	Performance criteria	Training topics	Learning outcomes
A.1 Follow workplace procedures for hazard identification and risk control.	A.1.1 Hazards in the work area are recognised and reported to designated personnel according to workplace procedures . A.1.2 Workplace procedures and work instructions for controlling risks are followed accurately.	Topic 1 The safety law Topic 2 Health and hygiene Topic 3 Recognising safety hazards Topic 4 Manual handling Topic 5 Hazardous substances Topic 6 Noise in the workplace Topic 7 Machine and equipment safety Topic 8 Personal protective equipment Topic 9 Working in confined spaces	Recognise and report hazards Identify and follow safe work practices Recognise hazards and causes ie, physical, chemical, mechanical and environmental Recognise, identify and obey safety signs Understand safety law and hierarchy of controls Report hazardous conditions
	A.1.3 Workplace procedures for dealing with accidents, fires and emergencies are followed whenever necessary within scope of responsibilities and competencies	Topic 1 The safety law Topic 3 Recognising safety hazards Topic 10 Emergency procedures Topic 11 Claims management and rehabilitation	Understand emergency procedures and follow instructions Prevent fire and follow control procedures Identify designated personnel and report accident and injury Locate first aid facilities in the workplace
A.2 Contribute to participative arrangements for the management of occupational health and safety.	A.2.1 Occupational health and safety issues are raised with designated personnel in accordance with workplace procedures and relevant occupational health and safety legislation.	Topic 1 The safety law Topic 3 Recognising safety hazards Topic 4 Manual handling Topic 5 Hazardous substances Topic 6 Noise in the workplace Topic 7 Machine and equipment safety Topic 8 Personal protective equipment Topic 9 Working in confined spaces Topic 10 Emergency procedures	Understand safety law and employer and employee responsibilities Understand role of health and safety representative and identify representative Understand and follow workplace safety procedures Recognise, identify and follow safety signs Identify and report hazards
	A.2.2 Contribute to participative arrangements for occupational health and a safety management in the workplace within organisational procedures and scope of responsibilities and competencies.	Topic 1 The safety law Topic 3 Recognising safety hazards Topic 4 Manual handling Topic 5 Hazardous substances Topic 6 Noise in the workplace Topic 7 Machine and equipment safety Topic 8 Personal protective equipment Topic 9 Working in confined spaces Topic 10 Emergency procedures	Understand the role and function of health and safety representative and health and safety committee Recognise and identify hazards and report to designated personnel Participate in hazard inspection

Resource Kit design

The Resource Kit has been designed with the needs of employees who have limited English language skills in mind, including people of non-English-speaking-background. However, it provides a useful OHS&W training approach for all employees. Assessment strategies were developed that were not dependent upon literacy skills, hence the listening activities at the end of each topic.

The Kit is divided into twelve topics with a pre and a post-evaluation review.

The pre-evaluation seeks to quantify the extent of knowledge and skills in both safety and English that trainees have on entering the course. This same data is collected again at the end of the course as a way of measuring learning improvement or, more pertinently, confidence from the perspective of the learner.

The use of pre and post-evaluation starts the competency-based assessment process in a non-threatening manner, and gives the trainer guidelines on training needs from the learner's perspective.

Each of the twelve topics is then divided into three clear sections:

- topic content
- listening activity
- developing writing skills.

Topic Content

When the Kit was trialed, all topics were covered as the trainees had had little exposure to formal safety training, in particular, the terminology. Eleven sessions of three hours each (36 hours in total) were allocated for each group of trainees. There were twelve to fifteen trainees in a group with low to intermediate levels of literacy. However, it may be appropriate in other worksites to pick and choose topics to customise a shorter program. It would also be possible to select sections from the package to supplement a broader language or literacy program.

Each topic has activities built into it that are designed to draw on knowledge developed in the workplace such as:

- identifying hazards in your work area
- work station inspections for manual handling
- listing hazardous substances at work
- explaining evacuation procedures.

Listening Activity

At the end of each topic there is a listening activity that is centred around a story or dialogue typical of a manufacturing environment. The listening activities are best used without the aid of the written text in the first instance for two main reasons: firstly, to assist in the development of aural skills, and secondly, to assure assessment that does not rely on written skills.

Responses to the listening activities, and the subsequent discussions about the potential issues that they relate to, are an important gauge of a trainee's competence.

The compact disc (CD) in the front of the folder contains the eleven listening activities.

Developing Writing Skills

The listening activities are followed by a "key word list". The key words are the main words in the topic that the project team considered essential to comprehension of the given topic. Bi-lingual dictionaries were supplied during the trialing so that the trainees had the opportunity to reflect on the words and to develop their dictionary skills in a supportive environment.

The time that trainees spent on the key words and the subsequent section also allowed valuable time for one-to-one assessment and support on an as-needs basis. It also created an opportunity for trainees to assist each other and to recognise their multilingual skills.

The "key word list" is followed by a "syllable" page, which was designed with two main principles in mind; firstly, to allow practise of pronunciation and hence develop oral confidence; and secondly, to develop the spelling principle of breaking words down into their syllables. The needs of the trainees as individuals, or as a group, dictated the focus of this section.

The "word family" section has been designed mainly with the more intermediate trainee in mind. Its inclusion was useful as an extension activity for trainees who were keen to develop their grammar and their vocabulary. It was not considered an essential component of the package, nor was it designed with assessment against safety competencies in mind.

The final section of each topic has been varied so that the overall package does not seem tedious or overly predictable. There are a variety of activities designed to develop literacy skills and to familiarise trainees with the key words of the topic, including crosswords, general grammar exercises, and incomplete sentences.

Preparing the resources for training sessions

The Resource Kit has been designed so that trainers can photocopy the material for the purpose of training. During the trial we found it less threatening to hand out each topic as we went. We photocopied the topic content sections in white and the listening activity and writing section separately and in blue. In this way we were able to use the listening activity as an assessment task without the written dialogue. We then handed out the "blue" section as a separate activity whereby the trainees learned to recognise the pattern of the design and to look forward to the opportunity to develop their writing skills. Certain trainees preferred to take the written sections home in order to access family support. We considered this flexibility an important component of their overall learning program.

Customising the Kit to a specific workplace

Each trainer is encouraged to deliver these resources in their own preferred manner, however, we found that creating overheads was useful as were the following supplementary resources:

- sample signs
- Material Safety Data Sheets (MSDS)
- accident and incident forms
- workplace lists of departmental OHS&W representatives and evacuation wardens
- relevant policies and procedures
- key workplace speakers
- suitable videos
- available work areas for audit purposes

Additional information

Questions relating to the suitability and/or delivery of this training resource can be directed to:

Workplace Education Service
Adelaide Institute of TAFE
Telephone (08) 8207 8280
Facsimile (08) 8207 8231

Access and Equity Unit
WorkCover Corporation SA
Telephone (08) 8233 2406
Facsimile (08) 8238 5775
Email accessequity@workcover.com

The developers would also welcome any comment or feedback on the Workplace Health and Safety Training Resource Kit.

The Workplace Health and Safety Training Resource Kit can be purchased from WorkCover Corporation SA

Customer Centre
Telephone 13 18 55
Facsimile (08) 8233 2211

TTY calls (08) 8233 2574 (for people who are deaf or have hearing/speech impairments).

If you would like to speak to someone at WorkCover Corporation in your language please call the Interpreting and Translating Centre on (08) 8226 1990 and ask them to call WorkCover Corporation on 13 18 55. This interpreting Service is available at no cost to you.

General information on occupational health and safety, and workers rehabilitation and compensation is available on the Corporation's web site: **www.workcover.com**

Welcome to the Workplace Health and Safety Training Resource Kit.

This kit has been developed using the skills of the Access and Equity Program of WorkCover Corporation and the Workplace Education Service of Adelaide Institute of TAFE. It has been designed for learners in the workplace.

Workplace activities, listening tasks and writing exercises have been built into this training kit. We hope that this training helps you to understand the safety knowledge that you need at work as well as developing your English skills.

Please take the time to fill in the sheets on the next pages so that your trainer can learn more about you and your current skills.

Pre-evaluation

Name: _____

Organisation: _____

Date: _____

Gender: Male Female

Country of birth: _____

Years at school: _____

Please circle a number to answer the following questions.

How much do you already know about safety?

The safety laws

1	2	3	4	5
not very much		adequate		a lot

Health and hygiene

1	2	3	4	5
not very much		adequate		a lot

Recognising safety hazards

1	2	3	4	5
not very much		adequate		a lot

Manual handling

1	2	3	4	5
not very much		adequate		a lot

Hazardous substances

1	2	3	4	5
not very much		adequate		a lot

Noise problems in the workplace

1	2	3	4	5
not very much		adequate		a lot

Machine and equipment safety

1	2	3	4	5
not very much		adequate		a lot

Personal protective equipment

1	2	3	4	5
not very much		adequate		a lot

Working in confined spaces

1	2	3	4	5
not very much		adequate		a lot

Emergency procedures

1	2	3	4	5
not very much		adequate		a lot

Claims management and rehabilitation

1	2	3	4	5
not very much		adequate		a lot

How would you rate your English skills?

Speaking

1	2	3	4	5
very poor		average		very good

Listening

1	2	3	4	5
very poor		average		very good

Reading

1	2	3	4	5
very poor		average		very good

Writing

1	2	3	4	5
very poor		average		very good

Do you have any further comments?

Thankyou for taking the time to let us know about your current skills and knowledge. We will ask you the same questions at the end of your training as one way of measuring your learning.

Did you know... that laws exist to protect you at work?

In Australia, there are lots of laws that protect people.

Robbery



Court

Gun laws



Driving

The safety law is the... Occupational Health, Safety and Welfare Act.

It makes sure you are safe and healthy at work.

All workers, casual, part-time, full-time, contract and even students,
are protected by the safety law.

Who is responsible for making the workplace safe?

Everybody!



Who is responsible for what?

Managers, supervisors or team coordinators are responsible for making sure that you have:

a safe environment to work in

Some of the responsibilities include:

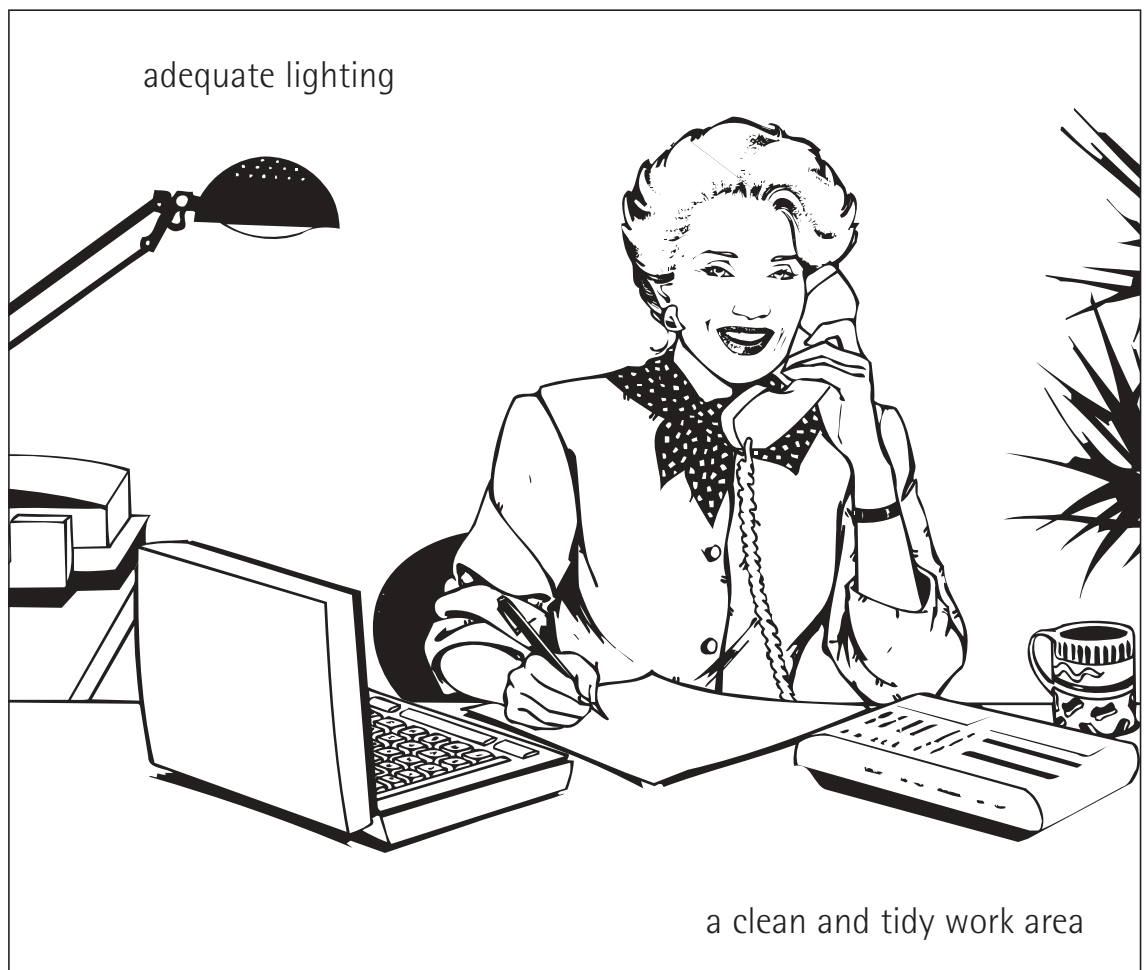

safe machines and materials

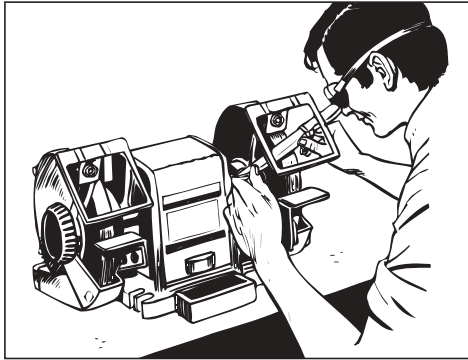

safety guards



chemicals stored separately

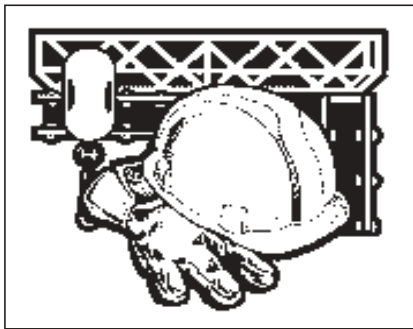

safety equipment



safety signs

safe working practices

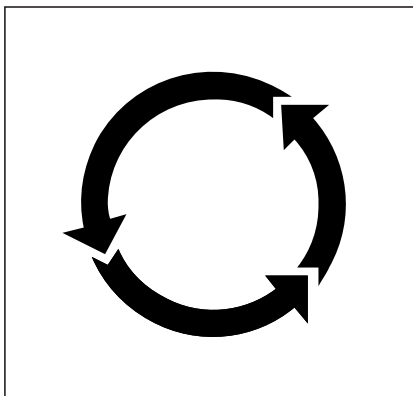

job rotation

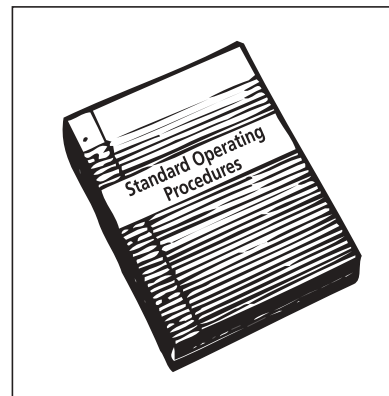

standard operating procedures (SOPs)

facilities for workers

lunch rooms

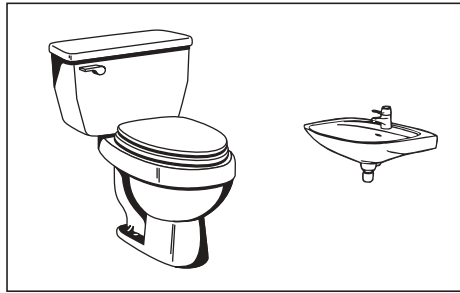
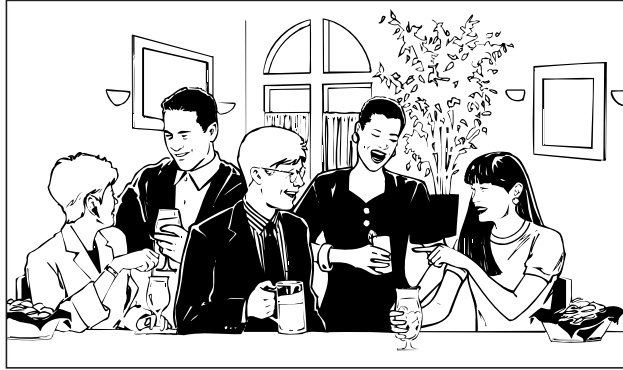

toilets and wash basins

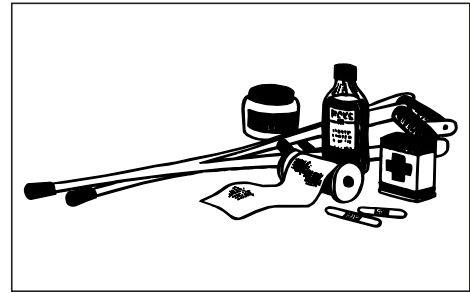

first aid equipment

information, instruction and training



This is in Section 19 of the Occupational Health, Safety and Welfare (OHS&W) Act, 1986 SA which says that providing a safe working environment is the duty of the Employer.

What are you... the worker, responsible for?

What do you need to do to make the workplace safe?

Match your responsibilities with the pictures

1

2

3

4

5

<p>Look after yourself at work Be Careful!</p>	<p>Think about the safety of other workers</p>	<p>Follow instructions</p>	<p>Use protective equipment</p>	<p>Not be affected by alcohol or drugs at work</p>
---	--	----------------------------	---------------------------------	--

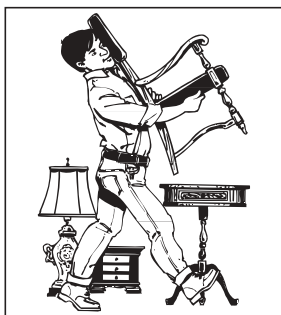
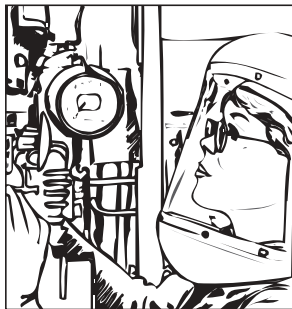

This is in Section 21 of the Occupational Health, Safety and Welfare (OHS&W) Act, 1986 SA which tells you what you have to do to stay safe at work

Safety signs

The signs and symbols that you see in the workplace are to help remind you or tell you about something.

Do you recognize any of these signs?



Safety signs

Do you know why some safety signs are different colours?

The red sign



The yellow sign

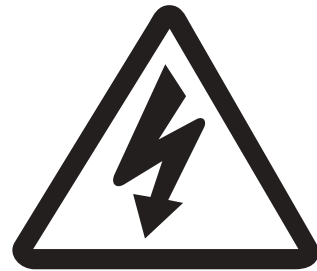

The green sign



The blue sign



Safety signs

Prohibition - You must not

Red circle sign with a diagonal line through it



Caution... Be careful

Yellow triangle



Mandatory - You must wear this

Blue circle with a picture inside



Emergency

Green square



Safety signs

Safety signs are there so everyone sees them and always obeys what they say. Everyone needs to understand them.

Safety signs can be different types

They can be pictures only



They can be words only



They can be both pictures and words



Safety Signs

Draw three signs that you remember from where you work.

What do they mean?

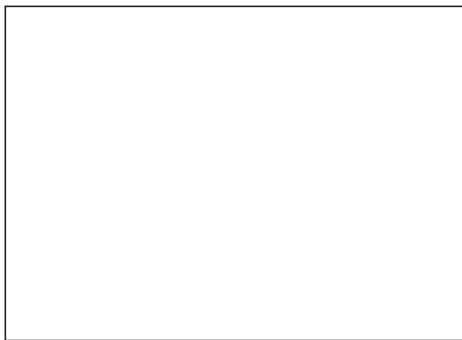





Activity

Draw a line to match safety pictures with their correct words.

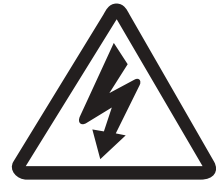

Beware radiation

First aid

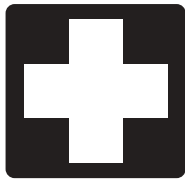

Breathing aparatus must be worn

Hearing protection must be worn

Beware electricity



Fire extinguisher

Beware forklift



Eye protection must be worn

Gloves must be worn



No smoking



How do you know if... your workplace is safe?

Make a list of some of the things that might be dangerous in your workplace.

Dangers at work

What do you have to do if you see something at work that might be dangerous?

You need to talk to

Your supervisor... or team coordinator... or team leader about the problem.

If the problem is not fixed, your health and safety representative may be able to help you.

Who is your... occupational health and safety representative (OHS rep)?

What do they do?

- Go to safety training.
- Help fix safety problems.
- Know the safety law.
- They are part of occupational health and safety committee meetings with managers and supervisors or team coordinators.
- The law gives the occupational health and safety representative power to fix safety problems.

Your OHS representative

Your occupational health and safety representative can communicate to managers and supervisors or team coordinators about health and safety problems. **This is called consultation.**

Consultation is about everyone having the chance to talk about how to fix safety problems in the workplace.

Consultation can happen through:

- workgroup and team meetings;
- occupational health and safety committee meetings;
- discussions with supervisors or team coordinators;
- discussions with your supervisor or team coordinator and the health and safety representative; or
- workplace audits and inspections.

Occupational health and safety committees

Health and safety committees are made up of workers and employers who meet to discuss health, safety and welfare in the workplace.

Health and safety committees assist in developing health and safety policies and consult with the employer on changes to policies or procedures.

At least half of the committee members must be workers.

The committee must meet at least every three months or sooner.

Members of the committee who represent workers are elected by the workers. They are usually health and safety representatives.

If your supervisor, team coordinator or health and safety representative cannot fix a safety problem, it should go to the committee to be discussed.



Listening activity

Van was walking through the factory on his way to the stores. He was happy to be at work and was smiling as he thought about the weekend ahead.

When he went through what he thought was the new entrance he noticed the red safety sign but did not pay much attention.

Next thing he heard:

"Oy! What are you doing coming through that way?"

"Didn't you see the sign?"

"It says... No admittance!"

"That means you buddy!"

What did Van do wrong?

What do red safety signs mean?

What should Van do next time?

The safety law... key words

English

First language

law	_____	_____
protect	_____	_____
danger	_____	_____
occupational	_____	_____
responsible	_____	_____
adequate	_____	_____
sufficient	_____	_____
duty	_____	_____
representative	_____	_____
committee	_____	_____
consultation	_____	_____
prohibition	_____	_____
mandatory	_____	_____
caution	_____	_____

Developing your writing skills

Write out the key words breaking them into syllables.

Example: p r o / t e c t (2)

danger _____ / _____

occupational _____ / _____ / _____ / _____ / _____

responsible _____ / _____ / _____ / _____

adequate _____ / _____ / _____

sufficient _____ / _____ / _____

duty _____ / _____

representative _____ / _____ / _____ / _____ / _____

committee _____ / _____ / _____

consultation _____ / _____ / _____ / _____

prohibition _____ / _____ / _____ / _____

mandatory _____ / _____ / _____ / _____

caution _____ / _____

Developing your writing skills

How many more words can you find that belong to the same word family?

Example: law... (lawyer, unlawful, law-abiding)

protect

danger

occupational

representative

responsible

consultation

Developing your writing skills

Look at the following sentences. Choose the correct verb.

The first one is done for you

1. Today there (~~is~~/**are**) laws to protect your safety at work.
2. Team coordinators are responsible for making sure that you (**have/has**) a safe environment to work in.
3. Workers (**need/needs**) to follow instructions.
4. Everyone needs to (**understand/understanding**) safety signs.
5. Consultation (**is/are**) important if everyone is responsible for safety.

Body parts

Draw a line between the body parts and their name.

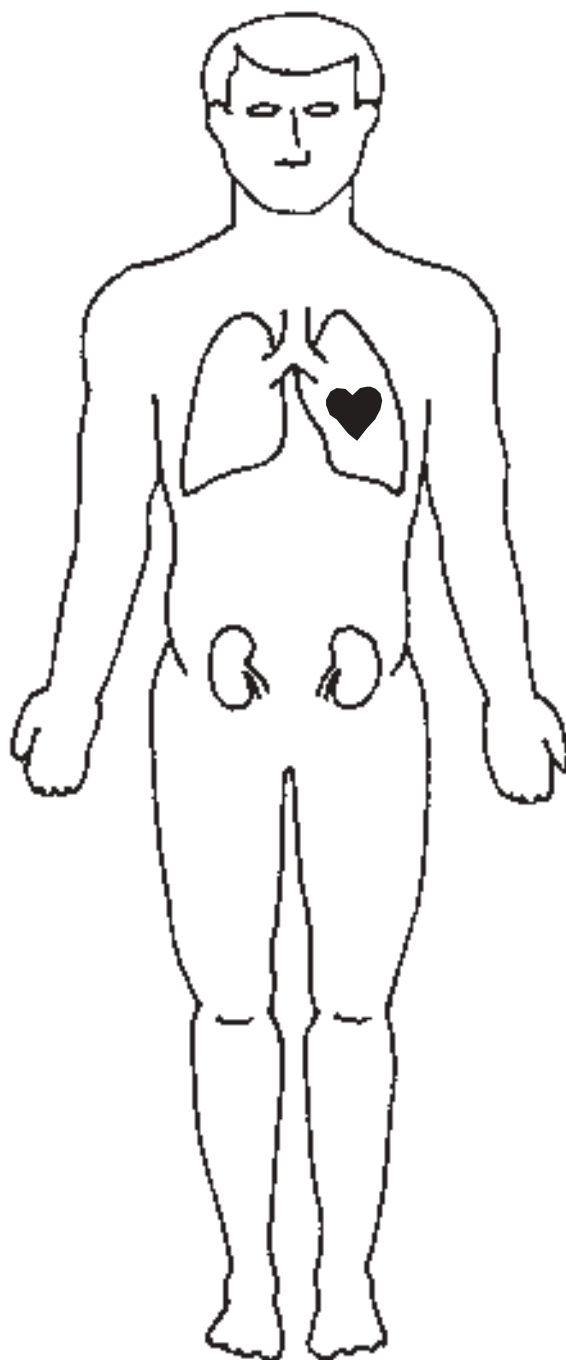

kidneys

ankle

shoulder

head

wrist

foot

knee

eye

neck

lungs

hand

heart

arm

ear

nose

stomach

Disease

Getting a disease is not like catching a cold. Diseases usually develop slowly. If you are aware of your body and notice any changes you might be able to get help before your health gets a lot worse.

If you are worried that you might be developing a disease, make an appointment with your doctor. They will talk things over with you and do some special tests to check your health.

Hygiene

Hygiene is about keeping yourself, food areas and toilet areas clean.

Why is keeping clean important?

There are germs and bacteria in the air and on surfaces that can make you sick. You can only see bacteria under a microscope.

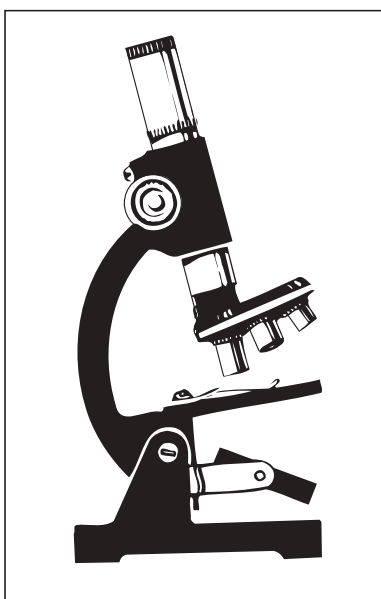

What sort of things can go wrong with your body?

Match the diseases or illnesses with the body parts they affect.

Disease/illness

Body parts affected

lung disease

any part of the body

arthritis

ears

hearing loss

spine

dermatitis

bones

migraines

lungs

back injury

head

cancer

skin

What can YOU do... to make sure that you don't spread germs and bacteria at home or in the workplace?



Make sure you wipe food benches with a clean cloth

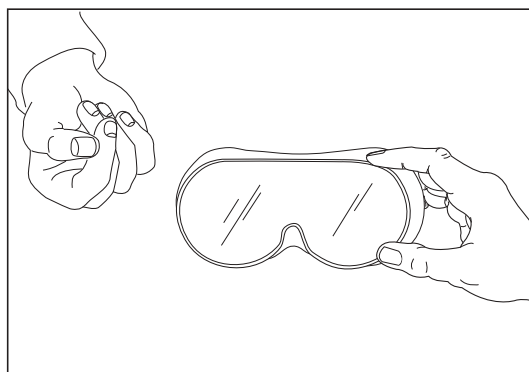

Don't share ear muffs, gloves or masks

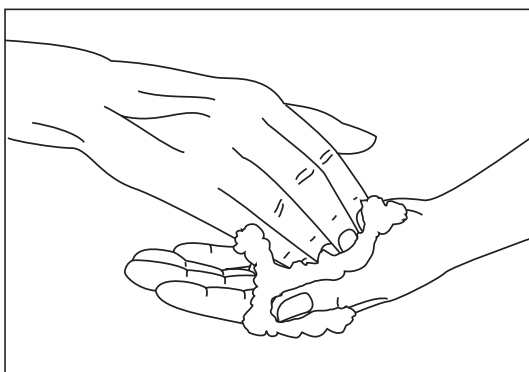

Wash your hands every time you use the toilet

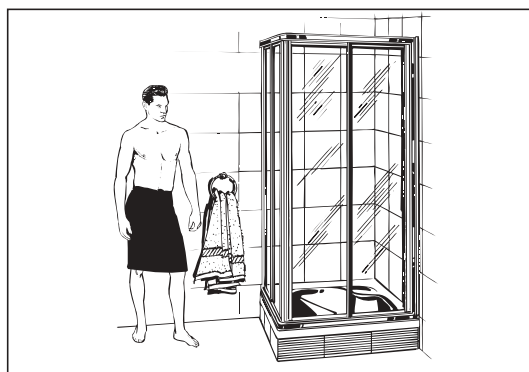

Shower regularly

Listening activity

Loui arrives at work for the afternoon shift on the carousel. There are a lot of airborne chemicals in the work area so he is always supposed to wear his mask.

Loui: "Hey Tony! Do you know where my mask is?"

Tony: "Joe's got it! You can have it in a sec when he's finished. Okay!"

Later that shift Loui starts sneezing and his eyes are watering. It seems he has caught the same cold that Joe has. Joe only borrowed Loui's mask because he had lost his and he was too worried to get another one from the stores. After all, Tony had said that the management wanted them to cut back costs.

Joe and Loui both ended up sick at home for two days with head colds.

Where should Loui keep his mask?

Is it okay to share masks?

What safety equipment is okay to share?

How do germs spread?

Health and hygiene - key words

English

First language

healthy

harm

hygiene

disease

illness

bacteria

spread

chronic

cancer

share

Developing your writing skills

Write out the key words breaking them into syllables.

Example: h e a l t h / y (2)

hygiene _ _ _ / _ _ _ _ _

disease _ _ _ / _ _ _ _ _

illness _ _ _ / _ _ _ _ _

bacteria _ _ _ / _ _ _ / _ / _

spread _ _ _ _ _

chronic _ _ _ _ _ / _ _

cancer _ _ _ / _ _ _

share _ _ _ _ _

Developing your writing skills

How many more words can you find that belong to the same word family?

Example: healthy ... (health, unhealthy, heal)

harm

hygiene

disease

spread

chronic

share

Crossword puzzle

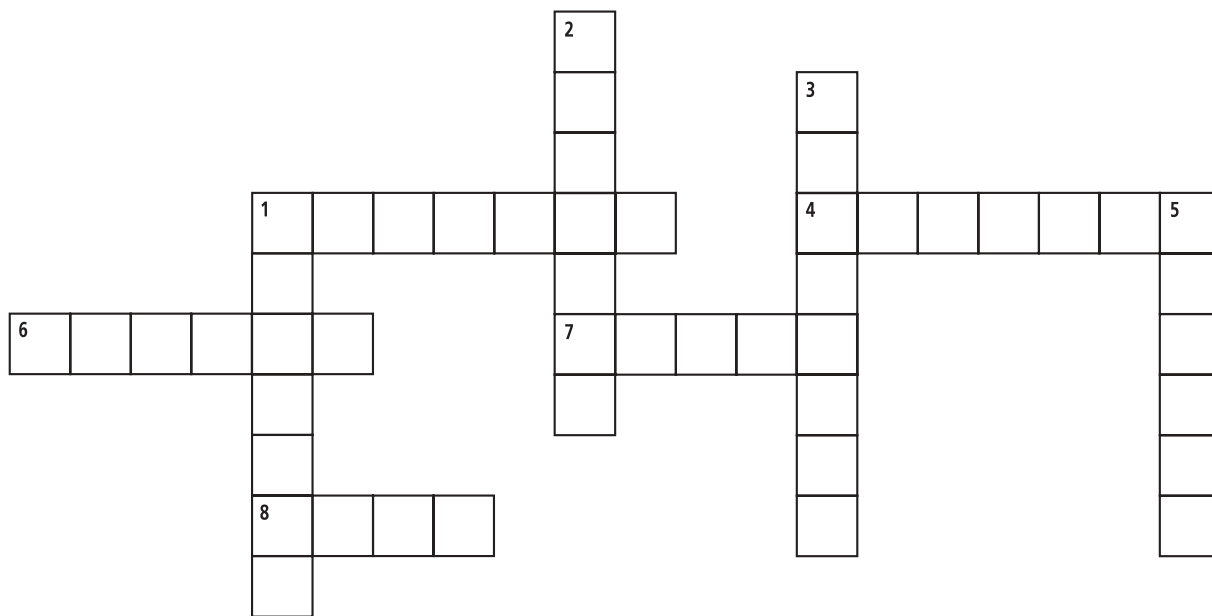

Across

1. This is important if you want to stop germs spreading.
4. If your illness does not go away it is called _____
6. When you sneeze you _____ germs.
7. If two people use something we say they _____ it.
8. Another word for hurt.

Down

1. If you are not sick you must be _____
2. If you get very sick you probably have an _____
3. You can only see this under a microscope.
5. This disease kills lots of people.

How do you know... if something in your workplace is a hazard?

Hazards are... dangers at work.

You might have a hazard to do with:

Machinery

Equipment

Raw materials

Workplace

Other workers

Your job

Poor housekeeping

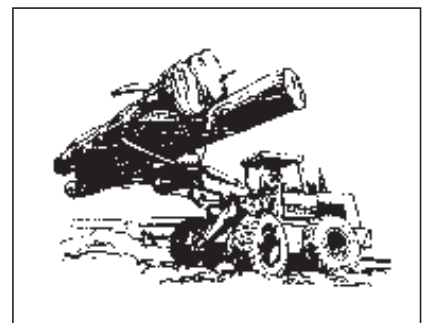

How can these things affect you... and make you less safe at work?

Machinery

You might work too close to machines that make lots of noise.

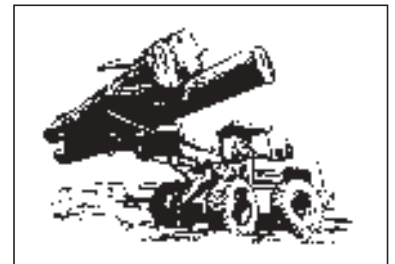

Raw materials

You might use chemicals or be near chemicals where you can breathe the fumes or where they could be spilled on your body.



Equipment

Equipment and tools may not be put away correctly and could fall down or people could get hit by them.



Workplace

There could be oil or water spilt on the ground where you work that could make you slip and fall.



Your job

In your job you may have to do a lot of lifting or twisting with your body or arms.

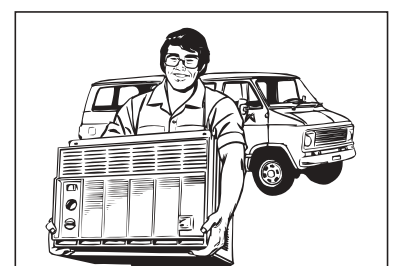

If you find a hazard at work... you must tell somebody

Supervisor / team coordinator

Health and safety representative

After you have told your health and safety representative and your team coordinator or supervisor that there might be a problem in your work area, they will need to come and have a look.

When Van found a hazard...

Van arrived at work at 6.00am and went to start work on the cutting machine. After preparing strips he checked the machine. He noticed that the guard rail was missing which was unusual. It was there last week.

Van told his team coordinator and Derek, the health and safety representative. As the three of them inspected the machine, they asked the following questions:

Why . . . was the guard rail off?

Who . . . was last working in the area?

Why . . . wasn't there a danger tag on the machine?

Were . . . there any messages in the log book?

Was . . . the cutting machine mentioned in the last safety inspection?

A nightshift worker told Van that they usually took the rail off to make it easier and quicker to clean out the machine. This way they were able to improve production by making an extra 15 parts per shift. Everyone seemed pleased with their extra output.

In small groups discuss the problems with this story about Van and the hazard.

How did... Van's team coordinator and his health and safety representative assess the risk with the cutting machine?

Firstly they gathered information about the problem. They asked lots of questions and spoke to a lot of other people.

They decided that there were two main reasons for the hazard:

1. The guard rail on the cutting machine was heavy and got stuck easily.
2. The workers on nightshift needed more training in recognising hazards.

They brainstormed the following ideas:

1. Get the boss to buy a new machine from Germany.
2. Change the guard rail for an infra red beam that will shut the machine down if people get too close.
3. Get maintenance to make a new guard rail that is not as heavy and doesn't get stuck.
4. Get the technical people to put up a new standard operating procedure (SOP) and teach all the workers how to use the machine.
5. Provide stronger gloves.

Then
 they looked at the hierarchy of
 control diagram that they got
 in training.

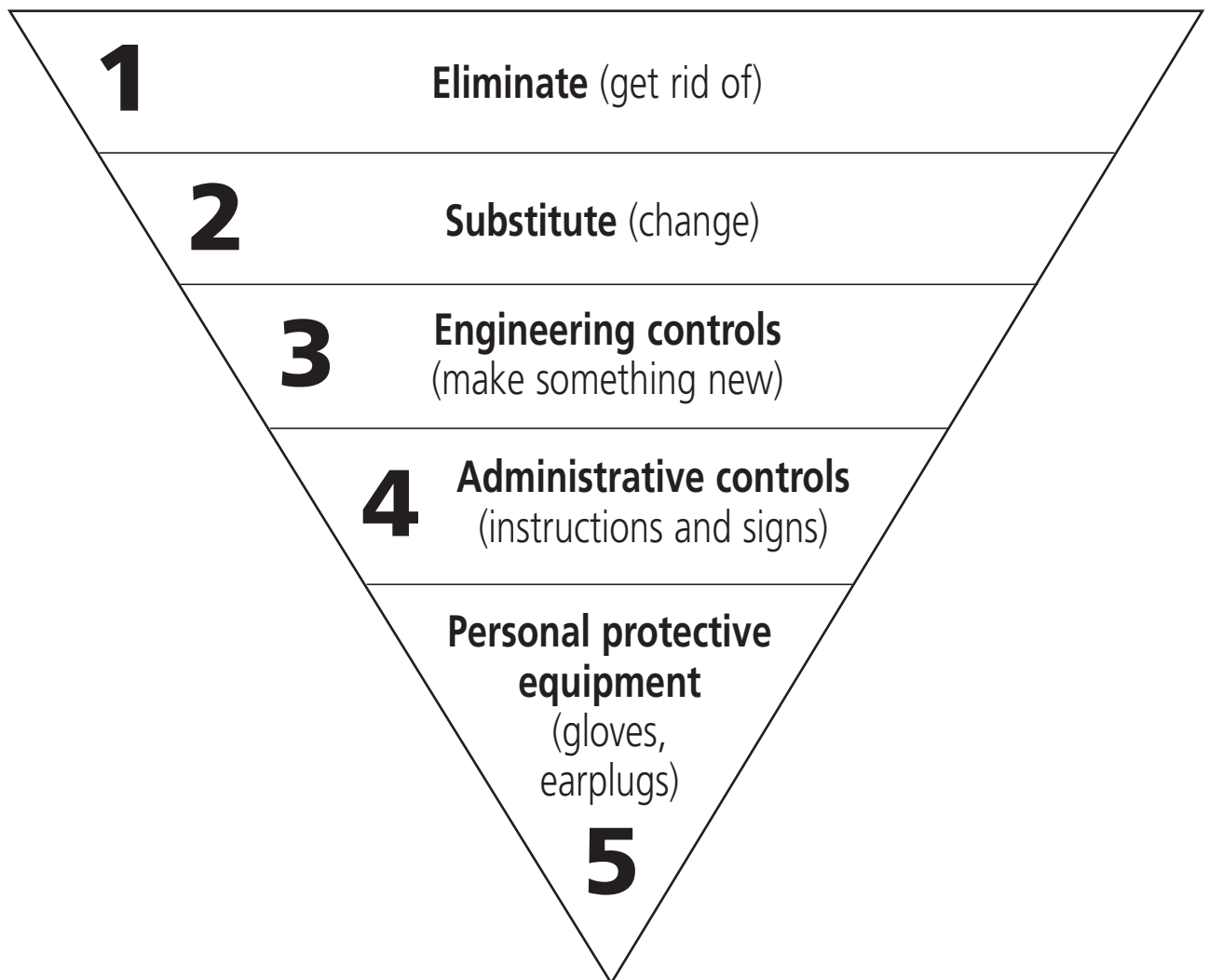

With all the ideas that they brainstormed, the health and safety representative told them what type of controls they were:

1. Get the boss to buy a new machine from Germany...

This control is called **elimination**. You stop the problem of having to clean the machine by getting one that cleans itself. *This is the best way to control the hazard.*

2. Change the guard rail for an infra red beam that will shut the machine down if people get too close...

This control is called **substitution**. You can stop the problem of people not using the guard and hurting themselves because the machine will stop if they get too close. *This is the best way to control the hazard.*

3. Get maintenance to make a new guard rail that is not heavy and doesn't get stuck...

This control is called **engineering**. You stop the problem of having to lift the heavy guard rail so that it is lighter and easier to lift when you have to clean the machine. *This is the best way to control the hazard.*

4. Get technical people to put up a new standard operating procedure and teach all the workers how to use the machine...

This control is called **administrative** and you can help the workers to make sure they use the machine the right way and keep safe. *This way of controlling the hazard depends on making sure everybody always uses the machine and the guard rail the right and safe way, but it is not the best.*

5. Provide stronger gloves...

This control is called using **personal protective equipment**. This way does not stop people from taking the guard rail off and keeping themselves safe when they clean the machine. *This way of controlling the hazard is the last choice. You could still hurt yourself if you don't use the guard rail when cleaning the machine.*

Match the ideas...

they brainstormed with the control measures. Draw a line to join together the ideas with the controls from best to last.

Ideas

Provide heavier duty gloves

Get the boss to buy a new machine from Germany

Get maintenance to make a new guard rail

Get the technical people to put up a new SOP and teach all the workers

Change the guard rail for an infra red beam

Control measures

Eliminate (get rid of)

Substitute (change)

Engineering controls
(make something new)

Administrative controls
(instructions and signs)

Personal protective equipment
(gloves, earplugs)

Circle the hazards that you can see

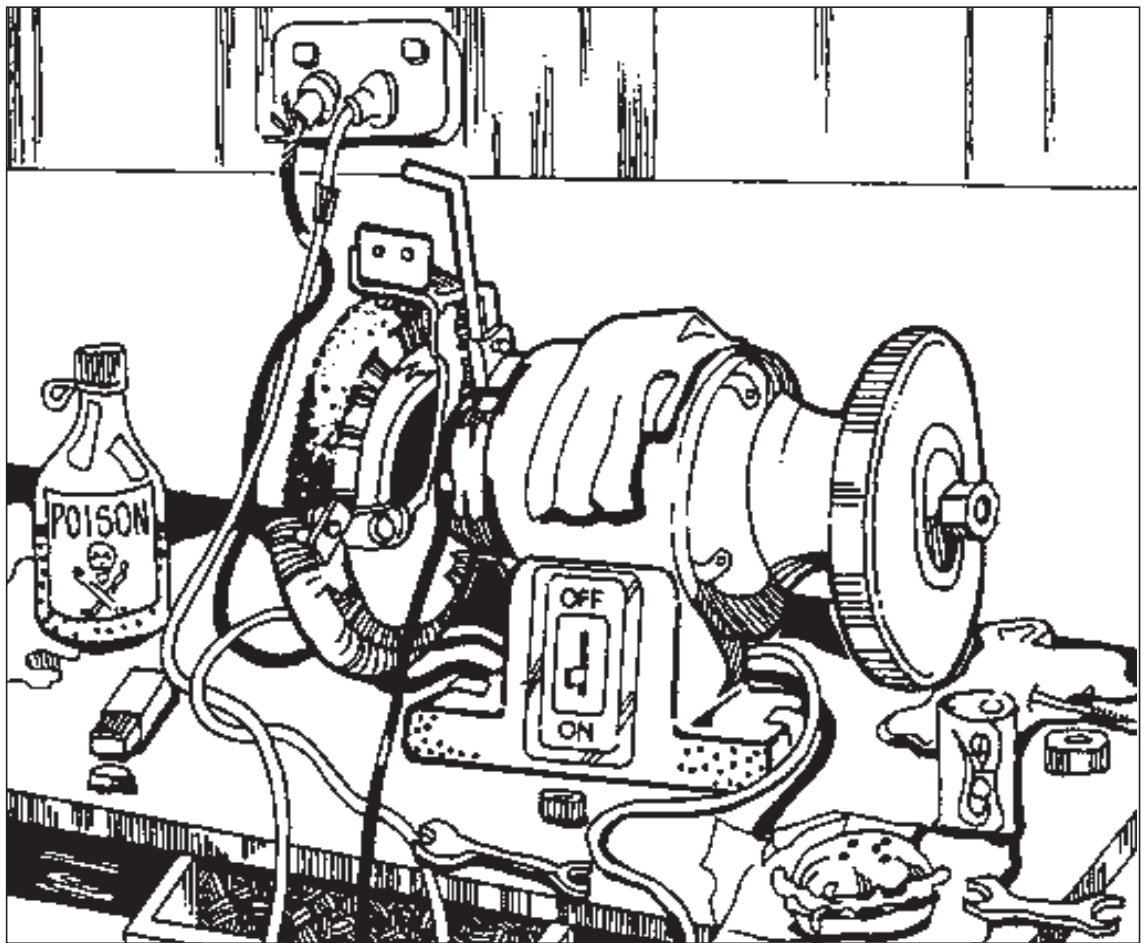

Who... would you report these hazards to?

Listening activity

Van was walking back to his work station when he noticed Minh closing the yellow electrical box near the finishing area.

Van: "Hi Minh! What are you doing there."

Minh: "Oh, I'm just putting my lunch box away in here. It's a lot easier than walking back to the lockers."

Van: "That's not a storage area Minh. That box is full of electrical wiring. You could electrocute yourself really easily!"

Minh: "But Sofia and I have been storing our things in here for months! Sofia says it's just the right size for her radio."

Van: "Well, you can't do that anymore. It's very dangerous. If you just touched one of those wires you'd get a 240 volt dose of electricity which would probably kill you."

Van was worried that Minh would think he was just dobbing her in to the supervisor. But it was such a hazard. He couldn't just ignore it.

What is the hazard that Van recognised?

What could be done to fix the problem?

What sort of control measure would you use?

Recognising safety hazards... key words

English

First language

hazard	_____	_____
affect	_____	_____
inspection	_____	_____
recognising	_____	_____
reporting	_____	_____
brainstorm	_____	_____
eliminate	_____	_____
substitute	_____	_____
engineer	_____	_____
administrative	_____	_____
control	_____	_____

Developing your writing skills

Write out the key words breaking them into syllables.

Example: h a z / a r d (2)

inspection _ _ _ / _ _ _ _ _ / _ _ _ _ _

recognising _ _ _ / _ _ _ / _ _ _ _ _ / _ _ _ _ _

reporting _ _ _ / _ _ _ _ _ / _ _ _ _ _

brainstorm _ _ _ _ _ _ _ / _ _ _ _ _ _ _

eliminate _ / _ _ _ _ _ / _ _ _ / _ _ _ _ _

substitute _ _ _ _ _ / _ _ _ _ _ / _ _ _ _ _ _ _

engineer _ _ _ / _ _ _ _ _ / _ _ _ _ _

administrative _ _ _ / _ _ _ _ _ / _ _ _ / _ _ _ _ _ / _ _ _ _ _

control _ _ _ _ _ / _ _ _ _ _ _ _

Developing your writing skills

How many more words can you find that belong to the same word family?

Example: affect... (affected, affecting, affection)

inspection

engineer

recognising

reporting

administrative

control

Developing your writing skills

Change the words in the brackets for an easier phrase from the box below.
The first one is done for you.

1. The supervisor decided to **(eliminate)** the cutting machine process.
1. The supervisor decided to **(get rid of)** the cutting machine process.
2. Van's idea was to **(substitute)** the guard rail for an infra-red beam.
3. The technician thought about **(engineering)** as a solution to the dangerous cutting machine.
4. We didn't want to rely on **(administrative controls)** to stop the workers from hurting themselves.
5. When a workstation is very noisy workers need to wear **(personal protective equipment)**.

get rid of

earplugs

change

making something new

written instructions

What is manual handling?



It is... picking up your child

It is... mowing the lawn

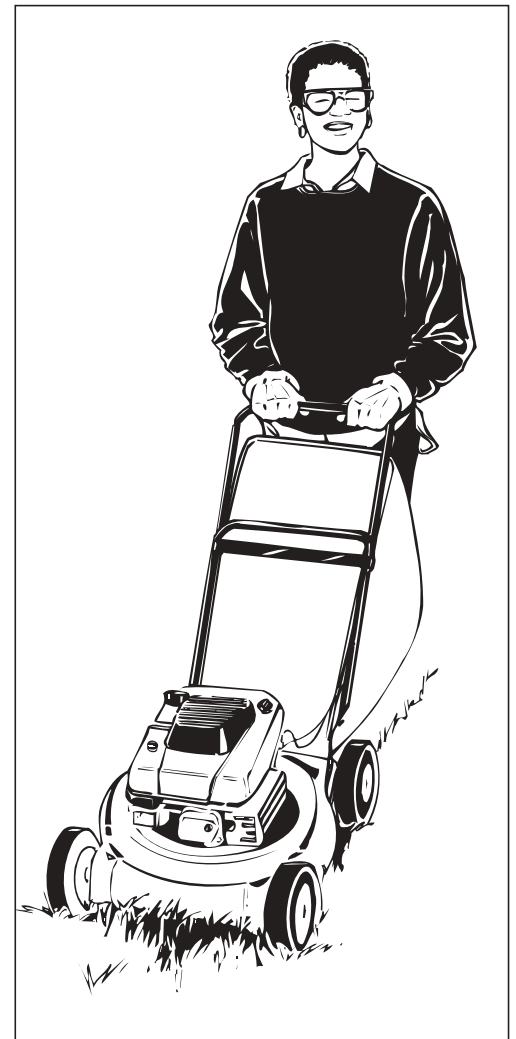

It is... going shopping and taking it home

Manual handling

What is... lifting?

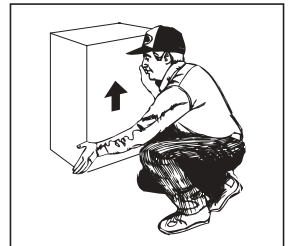

What is.... pushing?

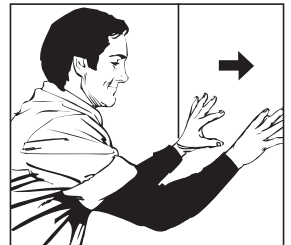

What is... pulling?

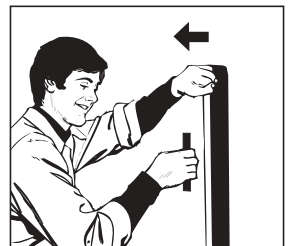

What is... lowering?

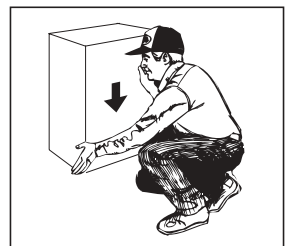

What is... carrying?

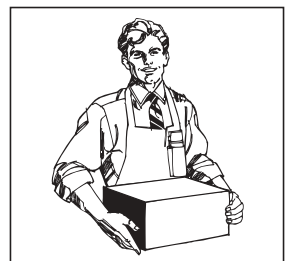

**When...
lifting, pushing, pulling,
lowering and carrying...
you need to be very careful -
you might hurt yourself**

You might cut yourself.

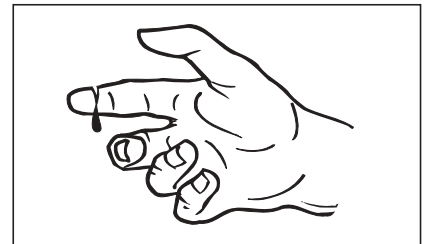

You might hurt your back, your spine
or your muscles.

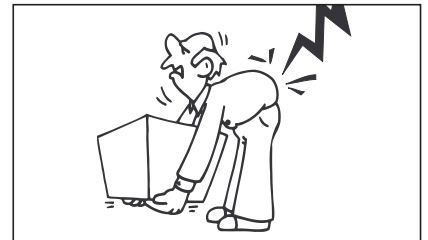

Your fingers, hand, arm or leg
might get hurt.

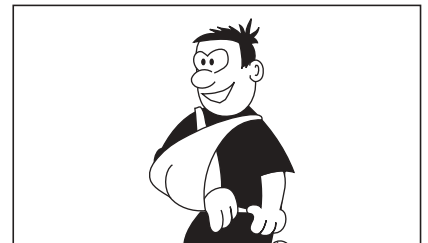

You might sprain your ankle.



Lifting, pushing, pulling and moving objects... can hurt your body

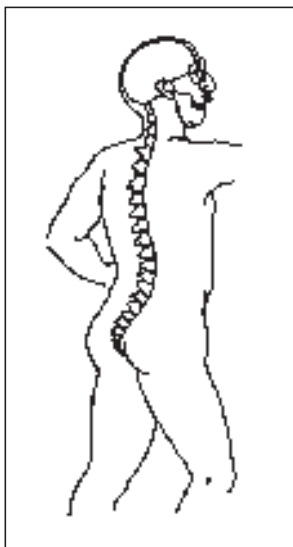

This is your back

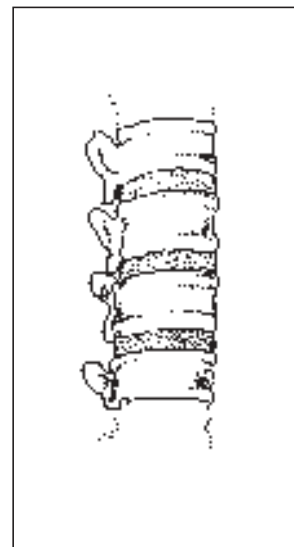

spine

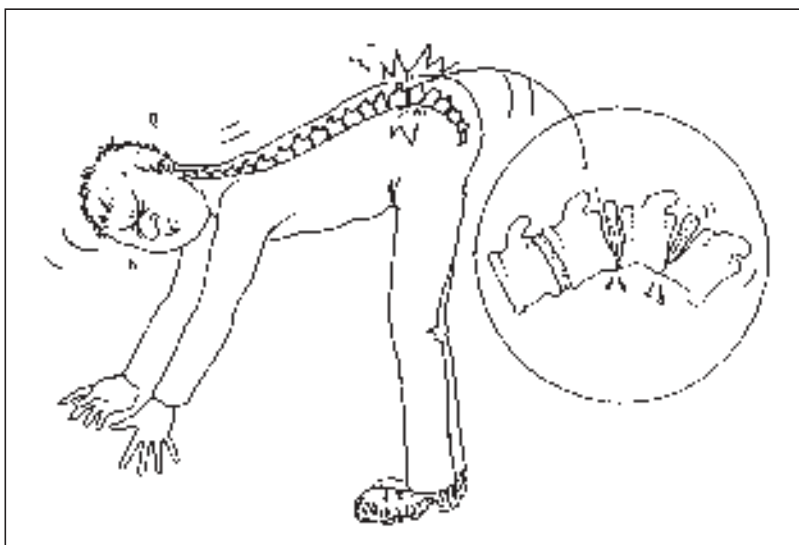

This is what can happen to your back

These parts of your body could be injured or hurt:

Skin

you can get cuts and bruises

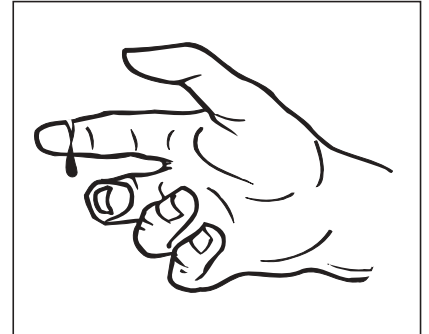

Muscles

you can sprain or strain your muscles



Bones

you might break your bones

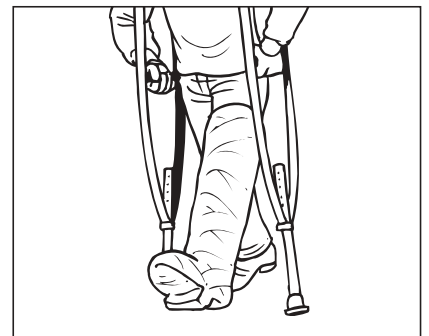





Spine

you might hurt your back

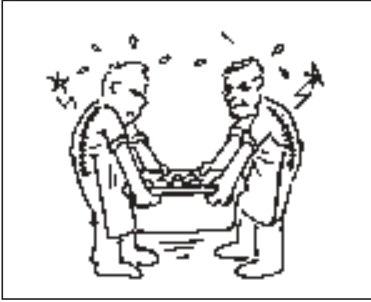
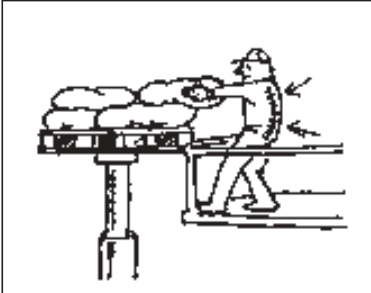
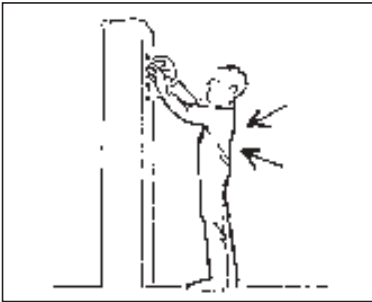
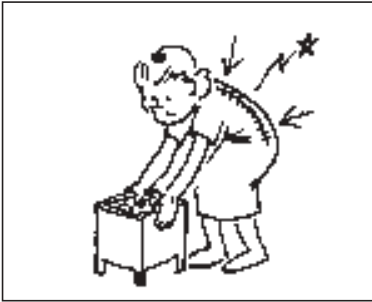
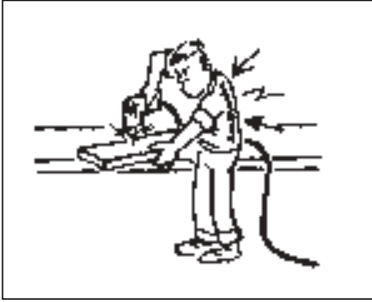

Do you do any of these jobs?

Please tick the appropriate boxes

<input type="checkbox"/>		<input type="checkbox"/>
<input type="checkbox"/>		<input type="checkbox"/>
<input type="checkbox"/>		<input type="checkbox"/>
<input type="checkbox"/>		<input type="checkbox"/>
		
		
		
		

These are some ways...

that you might do your work now and how you can change it so that you don't hurt yourself.

Problems



Lifting objects



Moving a drum

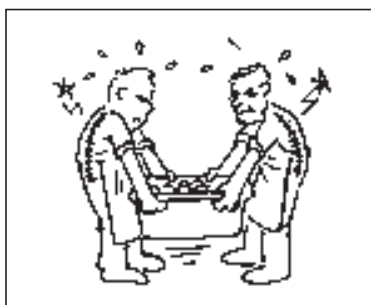

Two people are carrying a heavy tray

Solutions

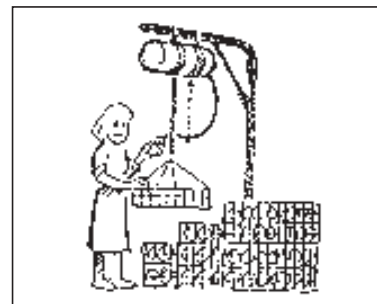

Using a machine... to lift the objects

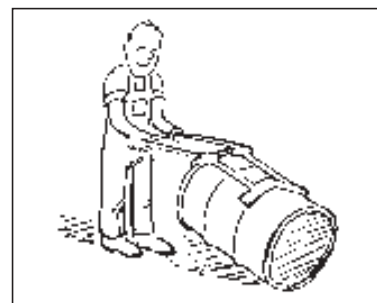

Using a drum tilting lever... to stand the filled drum up

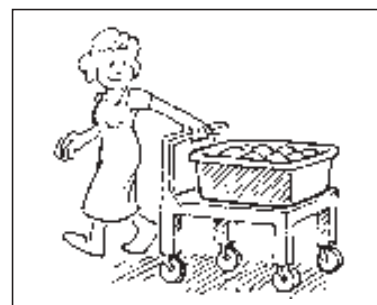

One person is wheeling the tray on a trolley

These are some ways...

that you might do your work now and how you can change it so that you don't hurt yourself.

Problems

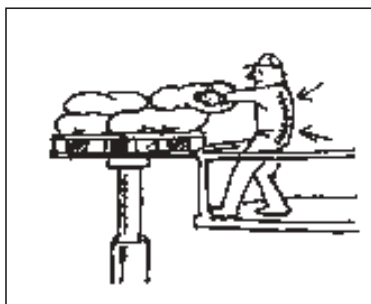

Unloading heavy bags from a pallet by hand

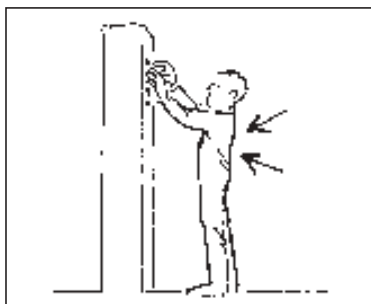

The buttons are above shoulder level

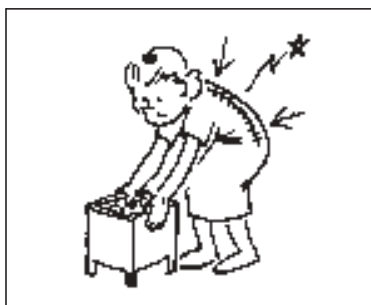

She has to lift the metal bin to empty it

Solutions

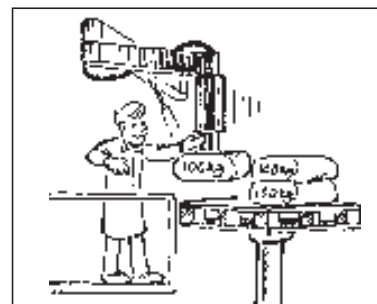

An electric machine unloads the bags from a pallet

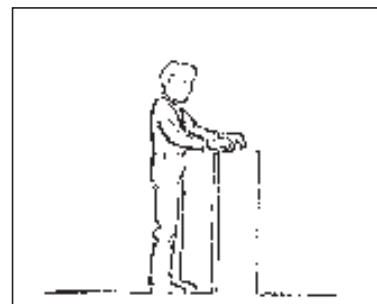

The buttons are below shoulder level



She only has to lift the plastic bag insert which is inside the bin

Individual lifting

If you have to lift anything, this is the way to make sure that you don't hurt yourself.

Plan the lift. If the load is too heavy, get help.

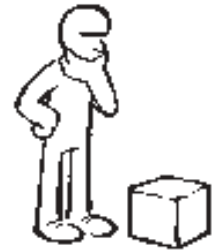

If possible, place your feet apart.



Bend your knees and hold the load firmly with both hands.



Raise your head and pull your chin in to keep your back straight.



Lift the load to your waist slowly by straightening your legs, keeping your elbows close to your body.



To put the load down, bend your knees and keep your back straight.



Objects...

Come in lots of different shapes and sizes.

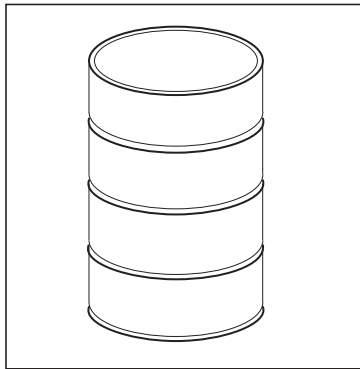

drum

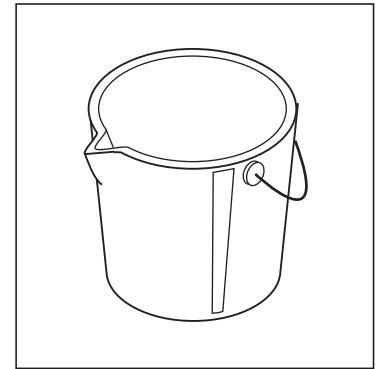

bucket with handle

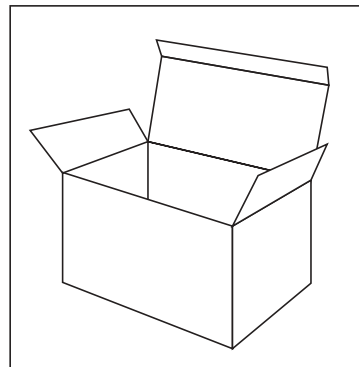

packing box

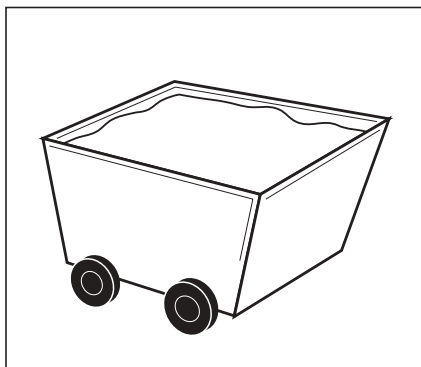

long bucket

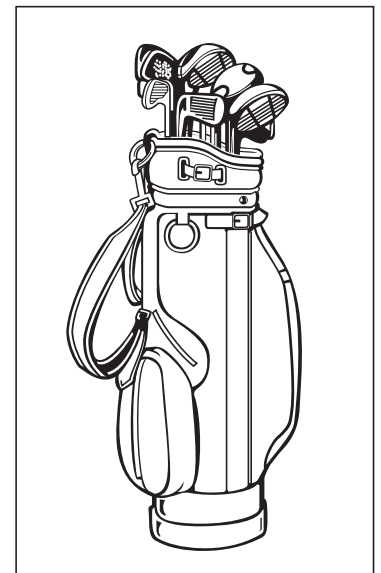

golf bag

How would you move these objects safely?

Pick the pictures...

that show the best way to do things. Draw a line to join them together.

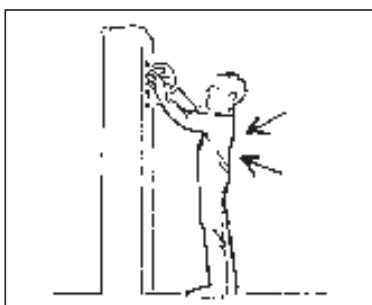
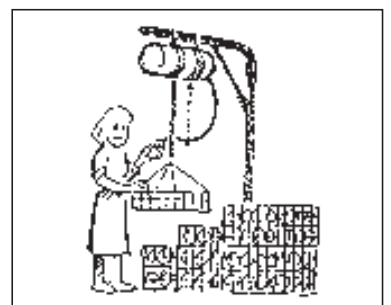
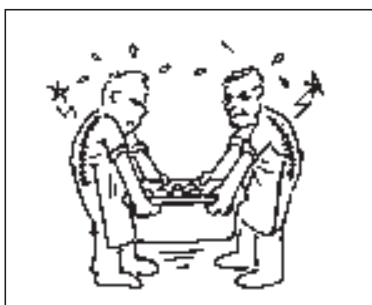
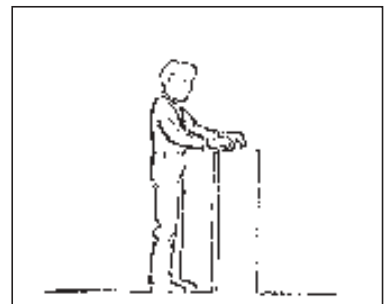
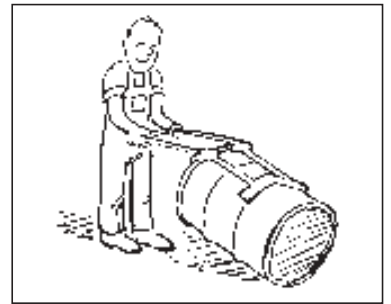
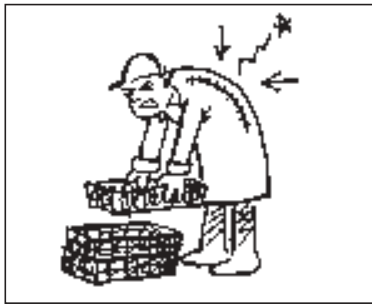

If you feel pain in... your back, shoulders, legs, arms, or hands when doing your work...

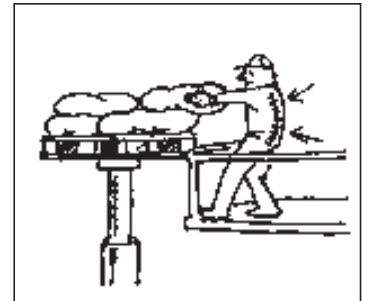

you need to tell someone before your pain gets worse.

You need to tell your...

Health and safety representative
and....your supervisor.

They can help you to change
what you do so that you don't
hurt yourself.



Workplace activity

Think of a job you do where you could hurt your back, arms or legs.

Why is there a risk?

Do you have to reach too high?

Do you have to carry heavy things?

How could you change this job to make it safer?

Listening activity

Mira had just transferred to a new department where she was making small metal parts, which she had to put into a bucket. Before she knew it the bucket was full. She filled in her paperwork and went to carry the bucket to the next section.

She stopped for a moment and thought about how she would carry it. After all it was a bit heavy and a bit awkward.

Later that shift Van came back to see Mira stretching up, almost jumping, to put some boxes away on top of the cupboard. He knew she was new so he spoke kindly.

"Mira, we always get some steps to put things up there. I'll show you where we keep them."

How could Mira carry the bucket safely?

What was Mira doing wrong?

Is Van supposed to help her?

Manual handling... key words

English

First language

skin	_____	_____
muscles	_____	_____
bones	_____	_____
spine	_____	_____
problems	_____	_____
solutions	_____	_____
trolley	_____	_____
risk	_____	_____
fracture	_____	_____
manual	_____	_____

Developing your writing skills

Write out the key words breaking them into syllables.

Example: m u s c / l e s (2)

bones _____

spine _____

problems _____ / _____

solutions _____ / _____ / _____

trolley _____ / _____

risk _____

fracture _____ / _____

manual _____ / _____ / _____

Fill in the gaps in the sentences

using the words from the list below.

Van had a _ _ _ _ _ with his job. He was finding it very difficult to push the _ _ _ _ _ . He did not want to take a _ _ _ _ with his _ _ _ _ . Van decided to talk to his supervisor.

They decided that the best _ _ _ _ _ was to replace the wheels on the trolley.

Use words from this list.

back

risk

solution

trolley

problem

Hazardous substances or chemicals...

can make you sick...

or injure you...

if you come in contact with them.



Some common products... that contain chemicals are:

petrol

alcohol

battery acid



glue

oil-based paint

cleaning products

dry-cleaning fluid

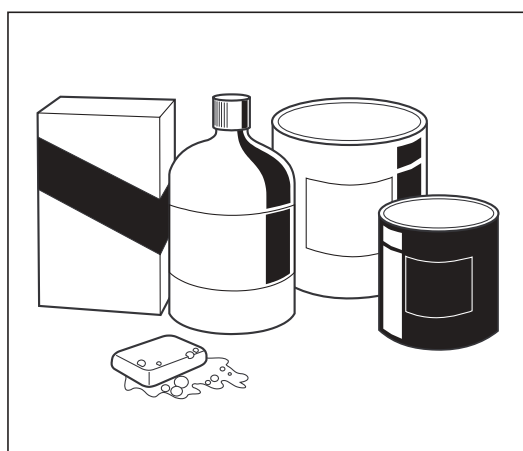

pesticides

cigarettes

hair dye

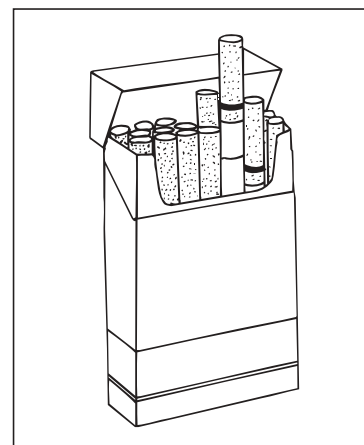

Label these parts of the body

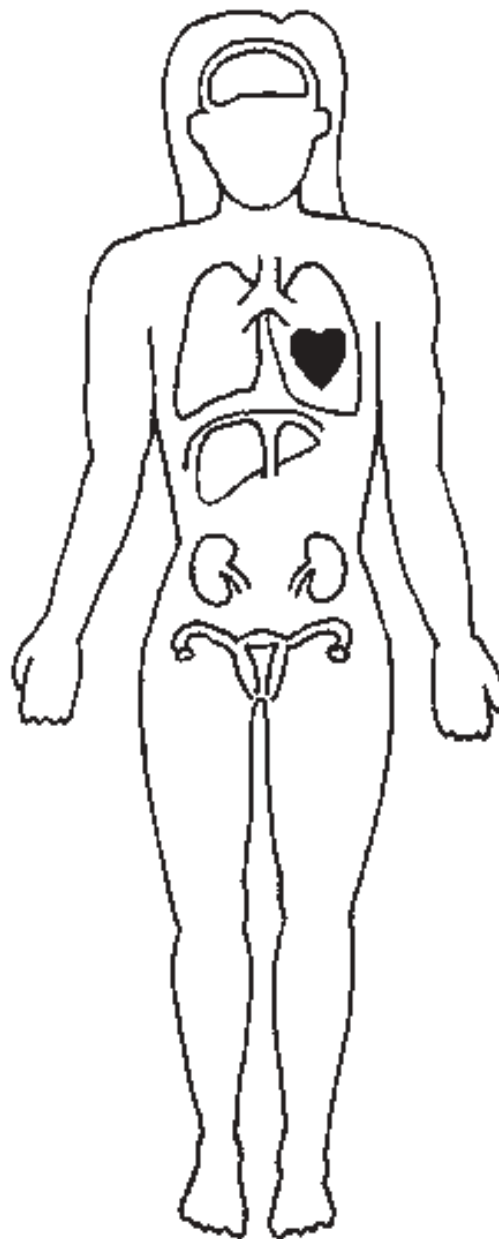

brain

eyes

lungs

kidneys

heart

liver

reproductive system
(female)

skin

Can you list some hazardous substances at work?

<hr/>	<hr/>
<hr/>	<hr/>
<hr/>	<hr/>
<hr/>	<hr/>
<hr/>	<hr/>

Do you know what these chemicals do to your health?

<hr/>
<hr/>
<hr/>
<hr/>
<hr/>

Do you know how to protect yourself from them?

<hr/>
<hr/>
<hr/>
<hr/>
<hr/>

Label each diagram correctly

1. Inhalation
2. Skin or eye contact
3. Eating or drinking

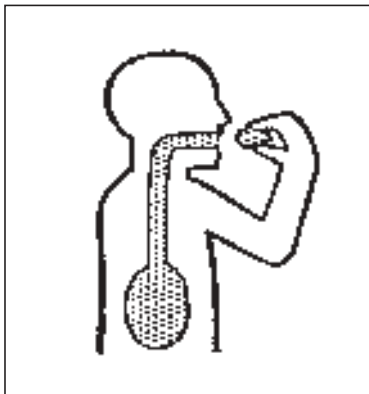

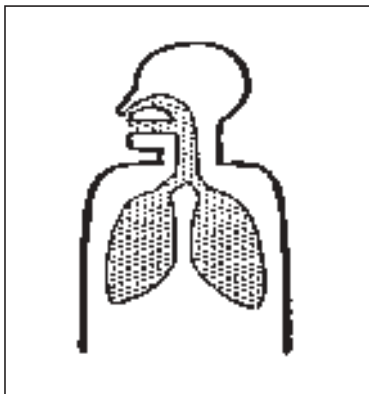

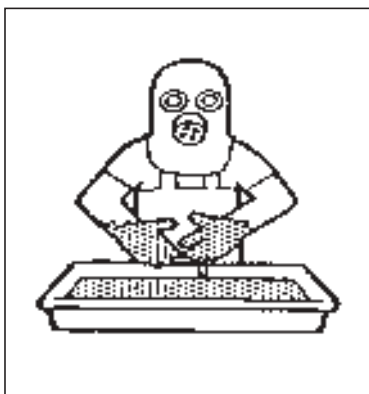

How do... hazardous substances enter the body?

Inhalation (breathing in)

Breathing in of vapours and dust is the main way that hazardous substances enter the body. In the lungs, chemicals are absorbed from the air directly into the bloodstream and are carried to all parts of the body. Dust particles are not absorbed into the blood, but they can penetrate the lung and remain there, causing a lot of damage.

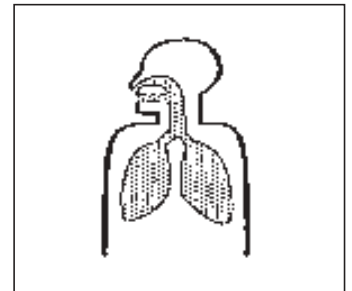

Skin or eye contact

Some chemicals can enter the body easily through the surface of the skin while others can enter through cuts or scratches on the skin.

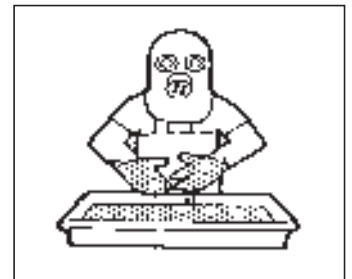

Eating or drinking

People can swallow food and drink which has been contaminated with chemicals in the workplace, or through chemicals on their hands. Dust particles in the air can be swallowed.

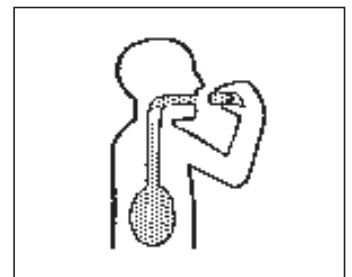

How does it affect you?

How do... chemicals affect your body?

headaches

dizziness

sleepiness

itchiness / rash



nausea (feeling sick)

burns to skin or eyes

vomiting

hard to breathe

coughing

cancer

unconsciousness

death



How do we... keep ourselves safe from these chemicals?

Know what you are working with!

You can find out information about a chemical from:

Material Safety Data Sheets (MSDS)

These will give you information on the chemical, its health hazards and how to handle it safely.

Your supervisor or team coordinator

Your health and safety representative

The chemical supplier

If you decide the chemical may affect you... you can

Eliminate...

the chemical

Substitute or replace...

the chemical with a safer one

Use engineering controls such as...

putting in good exhaust ventilation

Use administrative controls such as...

changing the way the job is done or
attending safety training

Use personal protective equipment such as...

wearing gloves or a mask

Personal protective equipment (PPE)

If you cannot eliminate, substitute or change the way you work with the chemical you need to wear your personal protective equipment (PPE).

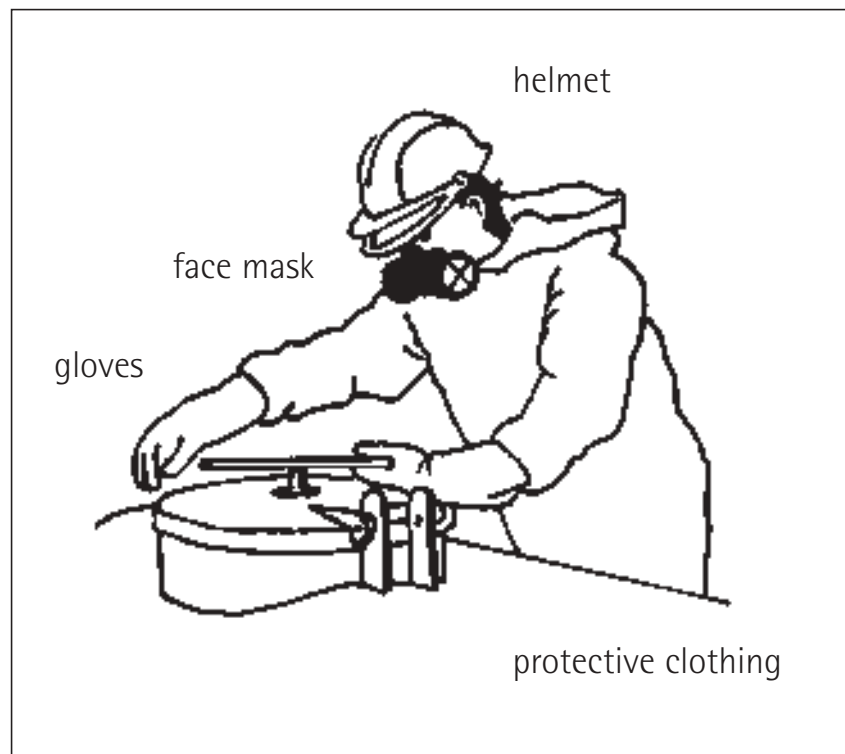

Listening activity

Minh decided that those thick green gloves were just too uncomfortable.

In her other department she had used cotton gloves. Why couldn't she use them here too?

Van: "Minh, why are you using those gloves? They're the wrong sort."

Minh: "But I prefer cotton gloves! Besides I'm not going to cut myself."

Van: "Minh, it's the solvent I'm worried about. Everytime you wipe down those parts you're touching MEK."

Minh: "Well then why don't we just use water?"

Van: "Water's no good. It marks the part. Minh, you don't want dermatitis do you?"

Minh: "I'm not worried - it's only for cleaning. It can't be that strong."

What did Minh do wrong?

Are solvents dangerous?

What should Van do?

Is there a better solution than gloves?

Hazardous substances... key words

English

First language

hazard	_____	_____
hazardous	_____	_____
substance	_____	_____
chemical	_____	_____
protect	_____	_____
inhale	_____	_____
contact	_____	_____
absorb	_____	_____
penetrate	_____	_____
contaminate	_____	_____
eliminate	_____	_____
substitute	_____	_____

Developing your writing skills

Write out the key words breaking them into syllables.

Example: h a z / a r d (2)

substance _____ / _____

chemical _____ / _____ / _____

protect _____ / _____

inhale _____ / _____

contact _____ / _____

absorb _____ / _____

penetrate _____ / _____ / _____

contaminate _____ / _____ / _____ / _____

eliminate _____ / _____ / _____ / _____

substitute _____ / _____ / _____

Developing your writing skills

How many more words can you find that belong to the same word family?

Example: hazard... (hazardous, hazardously)

chemical

protect

inhale

absorb

substance

contact

Fill in the gaps in the sentences...

Exposure to a _____ substance may cause illness or injury.

To _____ yourself from a hazardous _____ you should first try to _____ the substance.

You need to wear your personal protective equipment to ensure you do not _____ chemicals through your skin.

One way to check whether a chemical is a _____ to you, is to look at the Material Safety Data Sheet.

Use words from this list.

hazard

absorb

eliminate

substance

protect

hazardous

What is sound?

Sound is caused by the vibration of air particles like waves in the sea.

Noise is unwanted sound. Many workplaces are very noisy and this can affect your hearing over a long period of time.



The ear... how does it work?

The ear has three main sections - outer, middle and inner ear.

Label the diagrams to show:

- | | |
|--------------|------------------|
| 1 outer ear | 5 inner ear |
| 2 ear drum | 6 cochlea |
| 3 bones | 7 hairs |
| 4 middle ear | 8 auditory nerve |

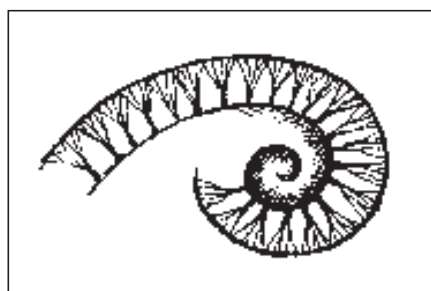
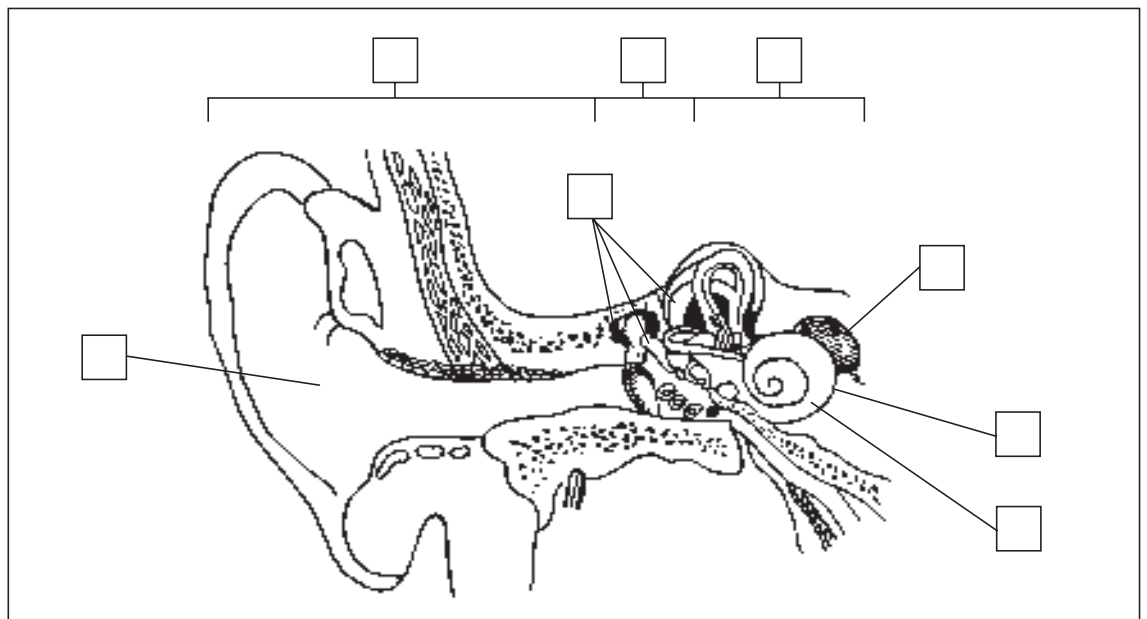

Cochlea of a person with normal hearing

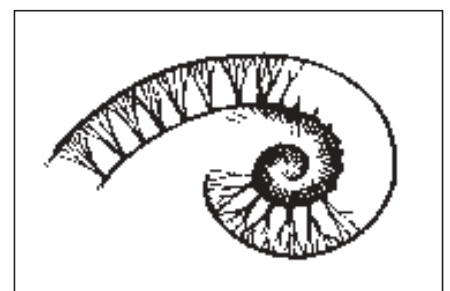

Cochlea of a person with severe hearing loss

The ear... how does it work?

When sound waves enter the ear they strike the eardrum making it vibrate. The vibration is passed on to three bones in the middle ear which vibrate the fluid in the cochlea. The tiny hair cells in the cochlea pick up the movement from the fluid and change it into electrical impulses for the brain.

The thousands of hair cells in the cochlea are like grass on a lawn. If the traffic on the lawn increases the grass is flattened. If the traffic stops for a while, the grass stands up again. However, if the traffic remains heavy, the grass will remain flat and will die off.

Too much noise will have the same effect on the ear.



When sound waves enter the ear they strike the eardrum making it vibrate.

Measuring noise

Sound intensity is measured in units called Decibels (dB). The following diagrams give examples of common noises and their decibel values from low to high. The chart below shows the noise levels produced by various noise sources.

Effect on people	Sound level in dB	Sound source
a lot of damage	140	Jet Engine
	130	Rivet Hammer
damaging	120	
	110	Chain saw
	100	Sheet-metal workshop
irritating	90	
	80	Heavy traffic
	70	
	60	Normal conversation
	50	Low conversation
	40	Quiet radio music
	30	Whispering
20	Quiet urban room	
	10	Rustling leaves
	0	Hearing threshold



Pain threshold



General standard in Australia for eight hours



If the sound level increases by three dB then the sound intensity doubles.

For example:

83dB is double the sound intensity of 80dB and can cause twice as much damage to your hearing.

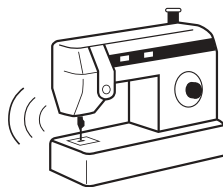

if 80dB

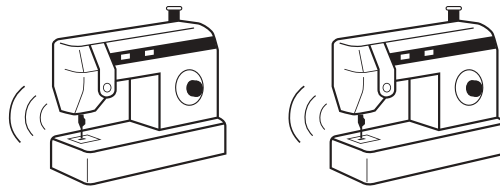

if 83dB

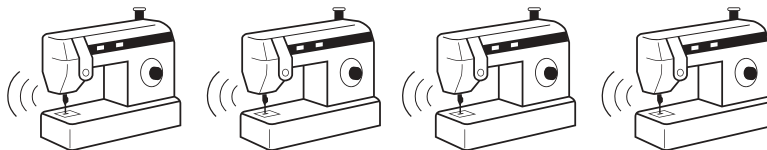

if 86dB

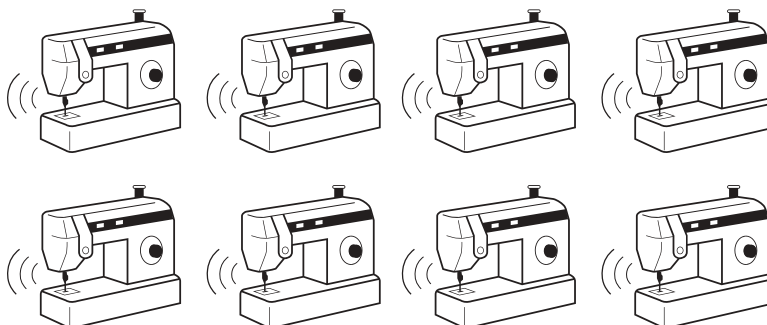

if 89dB

Measuring sound...

Intensity

measured in
decibels (dB)



Frequency

from *low*,
such as thunder



to *high*,
such as a chainsaw

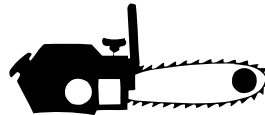

Exposure time

above 85dB for a
short time only

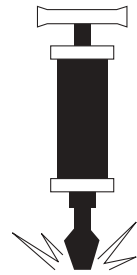

Hearing loss

If you have a hearing problem it can be either permanent or temporary hearing loss. You will probably not hear the higher frequency sounds.

Measuring noise at work

Noise is measured at work using a noise meter. It is important to measure the intensity and the frequency. This is done using a scale called decibels (dB).

A worker should not be continuously exposed to a noise level above 85 decibels.

What happens if the noise level is too high?

What happens if the noise level is measured and it is too high?

Remember... the different ways of controlling hazards.

Noise is a hazard so it is a problem to be solved like any other potential danger at work.

1. Isolate or enclose the sound

Eliminate or substitute.

2. Use engineering to change the machine

Engineering controls.

3. Use job rotation

Administrative controls.

4. Use hearing protection

Personal protective equipment.

Foundry case study

A foundry used air jets in its dye-casting plant to clean the finished castings.

Each casting was cleaned by blasts from six air jets and this produced noise levels of more than 108 decibels in peak periods.

Is a noise level of 108 decibels (dB) a workplace hazard?

What could they do to reduce the noise level?

Which of the five control measures did you choose?

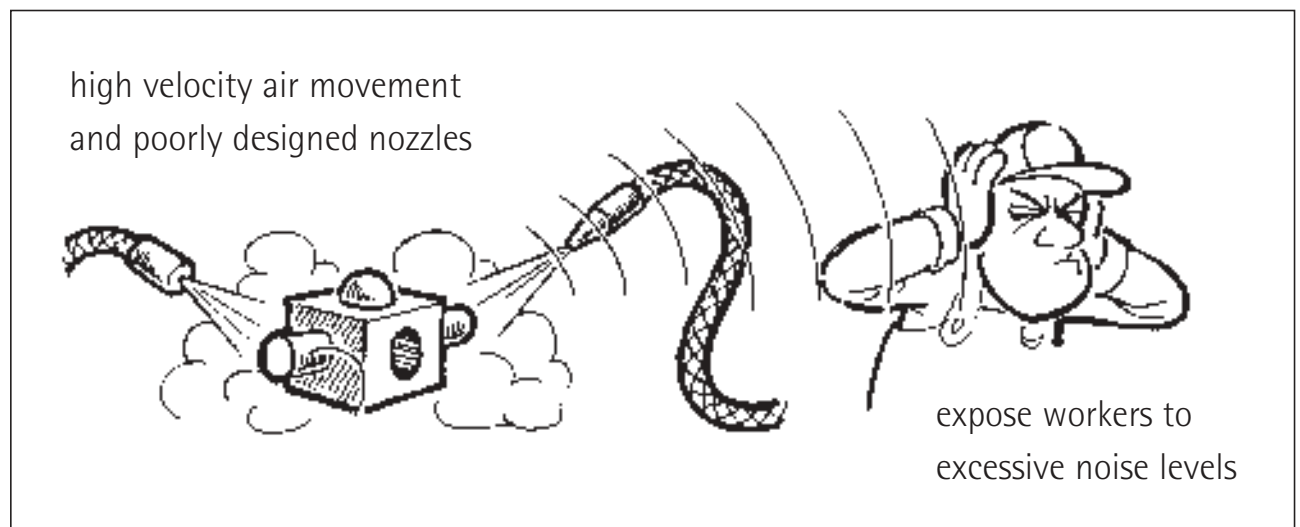

Possible solutions... to the foundry noise problem

1. Isolate the noise problem

by separating the worker from the air jets area.

Eliminate

2. Change the machine using engineering

by replacing the nozzles on each air jet.

Engineering control

3. Use job rotation

by moving workers through different jobs so they do not spend all day in the dye-casting plant.

Administrative control

4. Use hearing protection

by wearing ear muffs when working in the dye-casting plant.

Personal protective equipment

Activity

In small groups think of a noise problem in your workplace.

Try to come up with a solution by working through the four levels of control.

Safety tips... avoiding noise problems

What can you do to help yourself and others?

Close doors designed to reduce noise.

Report any noise problems with machines.

Make sure you know how to correctly use your ear protectors.

Have your hearing checked by a doctor.



Listening activity

When Frank finishes work on the assembly line he usually has a ringing in his ears. He also has a headache and is tired and irritable.

During the tea break he often sits on his own and reads the newspaper because he has difficulty hearing people talk in a group and often misunderstands what is being said.

At home his family complain he has the TV on too loudly.

His wife says he is becoming anti-social and rarely wants to go out with their friends. Frank just feels stressed.

What is the effect of excessive noise on Frank's life?

What other effects happen if you lose your hearing?

Noise in the workplace...

key words

English

First language

sound	_____	_____
noise	_____	_____
irritating	_____	_____
threshold	_____	_____
intensity	_____	_____
frequency	_____	_____
exposed	_____	_____
excessive	_____	_____
measuring	_____	_____

Developing your writing skills

Write out the key words breaking them into syllables.

Example: s o u n d (1)

noise _ _ _ _ _

irritating _ _ _ / _ / _ _ _ / _ _ _

threshold _ _ _ _ _ / _ _ _

intensity _ _ / _ _ _ / _ _ _ / _

frequency _ _ _ / _ _ _ _ _ / _ _

exposed _ _ / _ _ _ _ _

excessive _ _ / _ _ _ _ _ / _ _ _

measuring _ _ _ _ _ / _ _ _ / _ _ _

Developing your writing skills

How many more words can you find that belong to the same word family?

Example: sound... (soundless, soundlessly, soundly, unsound)

noise

irritating

intensity

frequency

excessive

measuring

Can you find the following words in the grid?

The first word has been done for you...

threshold	exposed	fluid	sound
intensity	impulses	irritating	noise
decibels	ear	bones	

i	r	r	i	t	a	t	i	n	g
d	f	a	n	b	w	h	b	w	e
e	l	b	o	o	p	r	l	s	e
c	u	c	u	n	i	e	o	l	a
i	i	n	t	e	n	s	i	t	y
b	d	e	q	s	d	h	e	a	r
e	w	x	e	x	p	o	s	e	d
l	p	i	m	p	u	l	s	e	s
s	o	s	o	u	n	d	w	s	e

Brainstorm...

all the machines and equipment that you can think of in your workplace.

_____	_____
_____	_____
_____	_____
_____	_____
_____	_____
_____	_____

Almost all the equipment, machinery and appliances that you use at work is called plant.

Except... manually powered tools such as:

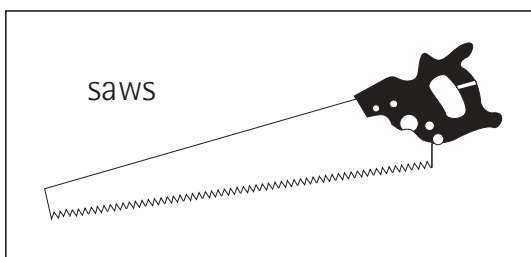
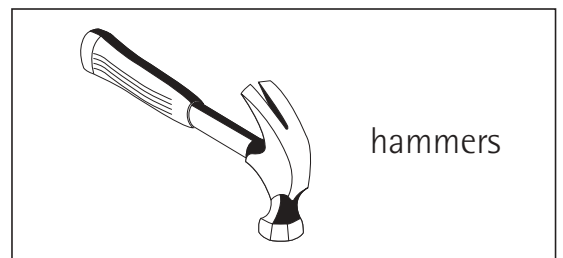
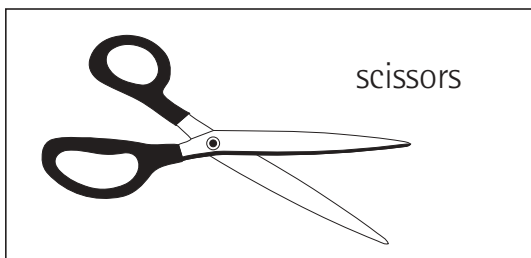

Hazards... are dangers at work

How many hazards can you think of in your workplace?

_____	_____
_____	_____
_____	_____
_____	_____
_____	_____
_____	_____

There are many hazards that affect machinery such as:

mechanical hazards

noise

vibration

heat

electrical hazards

chemical exposure

laser radiation

What have they done?

In the second picture of each pair, the operator has done something to make the job safer.



Machine and equipment hazards... can be divided into categories

Hazards	Examples
Physical	noise heat from the machine moving machinery repetitive jobs poor design
Chemical	solvents, cleaners, acids dusts and powders like asbestos fumes from hot metals, petrols and gases smells from paints, plastics and pesticides
Biological	rusty machine parts unclean work area and facilities
Psychological	long shifts without proper breaks
Electrical	broken or frayed cords exposed wires faulty electrical wiring

Hazards

A sewing machine is a piece of equipment that can be a hazard.



What sort of hazards do you have to be careful of with a sewing machine?

A press is another potential hazard.

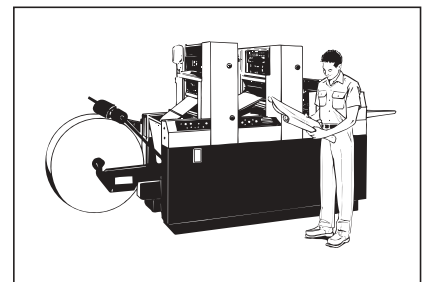

What sort of hazards do you have to be careful of with a press?

Machine guarding

Guards protect operators from getting their hands, hair or other parts of their body or clothing caught in a machine.

They also protect you from things flying out of the machine or falling objects.

There are four types of guards:

1. fixed guards;
2. interlocking devices which stop the machine when the guard is open;
3. two-button controls; and
4. sensory guards that are sensitive to movement.

What sort of guards are there in your workplace?

_____	_____
_____	_____
_____	_____
_____	_____
_____	_____
_____	_____

BE RESPONSIBLE!

REMEMBER
Never remove a safety guard.

Isolation and tagging procedure

Isolation: Power should always be turned off when maintenance people are fixing a machine. There will be a tag on the machine.

Here are some isolation tags.

Which ones have you seen in your work area?

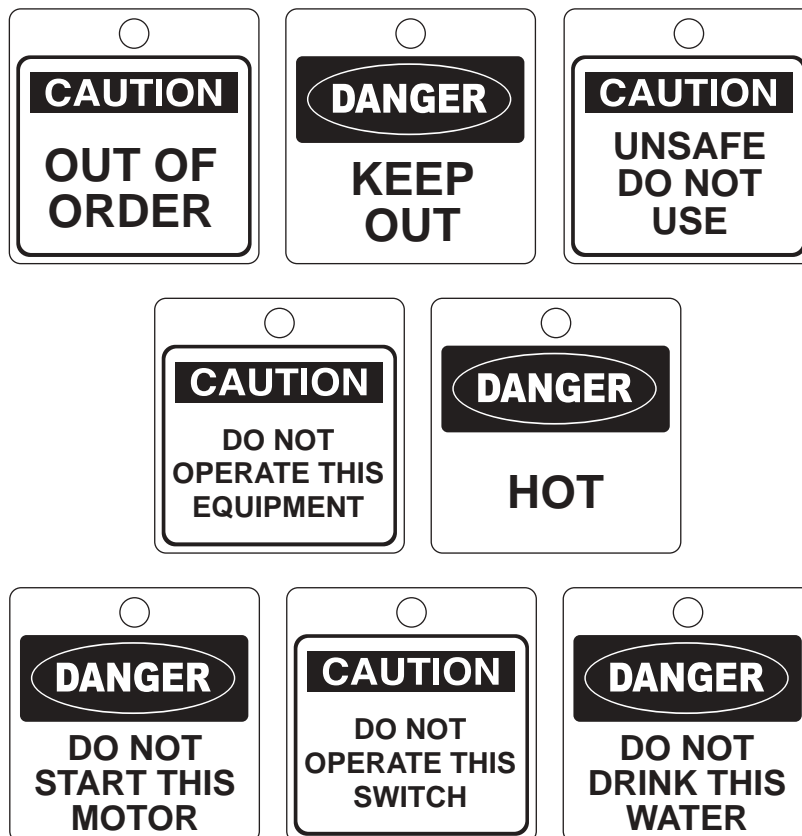

BE RESPONSIBLE!

Read and obey all tags that you find placed on products, tools, equipment or machinery.

What personal protective equipment do you wear in your workplace?



glasses



earmuffs



clothing



boots

BE RESPONSIBLE!

Wear the proper personal protective equipment.

Machine and equipment inspection

Work in a group of two or three people. Look at a work station with machines and equipment that people use. Think about the following questions and then discuss your answers when you return to the training room.

1. Names of group members _____

2. What is today's date? _____ / _____ / _____
3. What is the name of the work station? _____
4. Who is the supervisor or team coordinator for the workstation?

5. What jobs are you inspecting? _____

6. Is there enough space around the machine for people to work? Yes No
7. Are the guards in place? Yes No
8. Are the stopping and starting devices easy to reach? Yes No
9. Is the machine and the area around it clean? Yes No
10. How much noise can be heard from the machine? _____
11. Do people using the machine have to do any bending or reaching? Yes No
12. Is the bench height suitable for the people working the machine? Yes No
13. Is the floor around the machine clean? Yes No
14. Does anything fall from the machine such as drips, cut pieces of plastic or metal? _____

15. Has the operator been correctly trained in safe machine operation? Yes No

Listening activity

Tho had just transferred to a department where the presses didn't have light beams or guard railing. Instead they had a dual button system to avoid getting workers' hands caught.

That night at smoko...

Tim: "Hey Tho! Do you want to join the card club? We play every night."

Tho: "Sure, but is it after work?"

Tim: "No, we work faster here at night so we've got time for a game or two. You need to know a few tricks of the trade though!"

Tho: "What sort of tricks?"

Tim: "Well, instead of using those buttons, you can use your knee here and override the safety. You'll get a few more parts through that way and finish your quota earlier."

Tho was worried. He desperately wanted to make Tim a new friend but he did not want to risk his safety.

What should Tho do?

Machine and equipment safety... key words

English

First language

manual

radiation

physical

biological

psychological

isolate

caution

danger

guard

Developing your writing skills

Write out the key words breaking them into syllables.

Example: m a n / u / a l (3)

radiation _ _ _ / _ / _ / _ _ _ _

physical _ _ _ _ / _ / _ _ _

biological _ _ / _ / _ _ _ / _ / _ _ _

psychological _ _ _ _ _ / _ / _ _ _ / _ / _ _ _

isolate _ / _ _ / _ _ _ _

caution _ _ _ / _ _ _ _

danger _ _ _ / _ _ _

guard _ _ _ _ _

Developing your writing skills

How many more words can you find that belong to the same word family?

Example: radiation... (radiate, irradiate, radiator, radiant)

biological

isolate

danger

caution

guard

psychological

Fill in the gaps in the sentences...

Examples of _____ hazards are moving machinery and noise.

Machine _____ protect an operator from _____.

Isolation tags with the warnings "Danger" and " _____ " are attached to machines undergoing repair.

_____ tools are not called plant.

Use words from this list.

manual

guards

danger

physical

caution

What is... personal protective equipment?

Personal protective equipment is clothing or equipment that protects you while working!

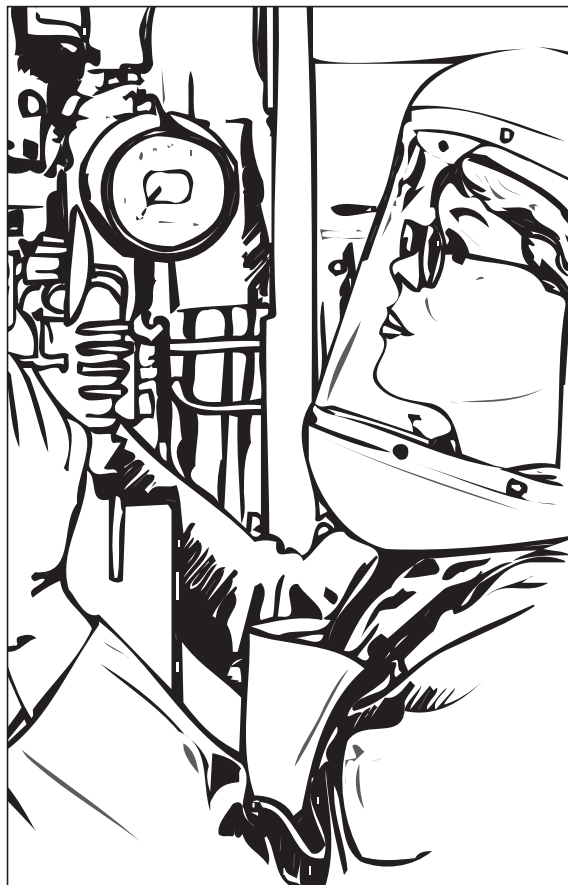

Head protection

Remember...

Personal protective equipment is the last measure of control. You should look at the other measures first.

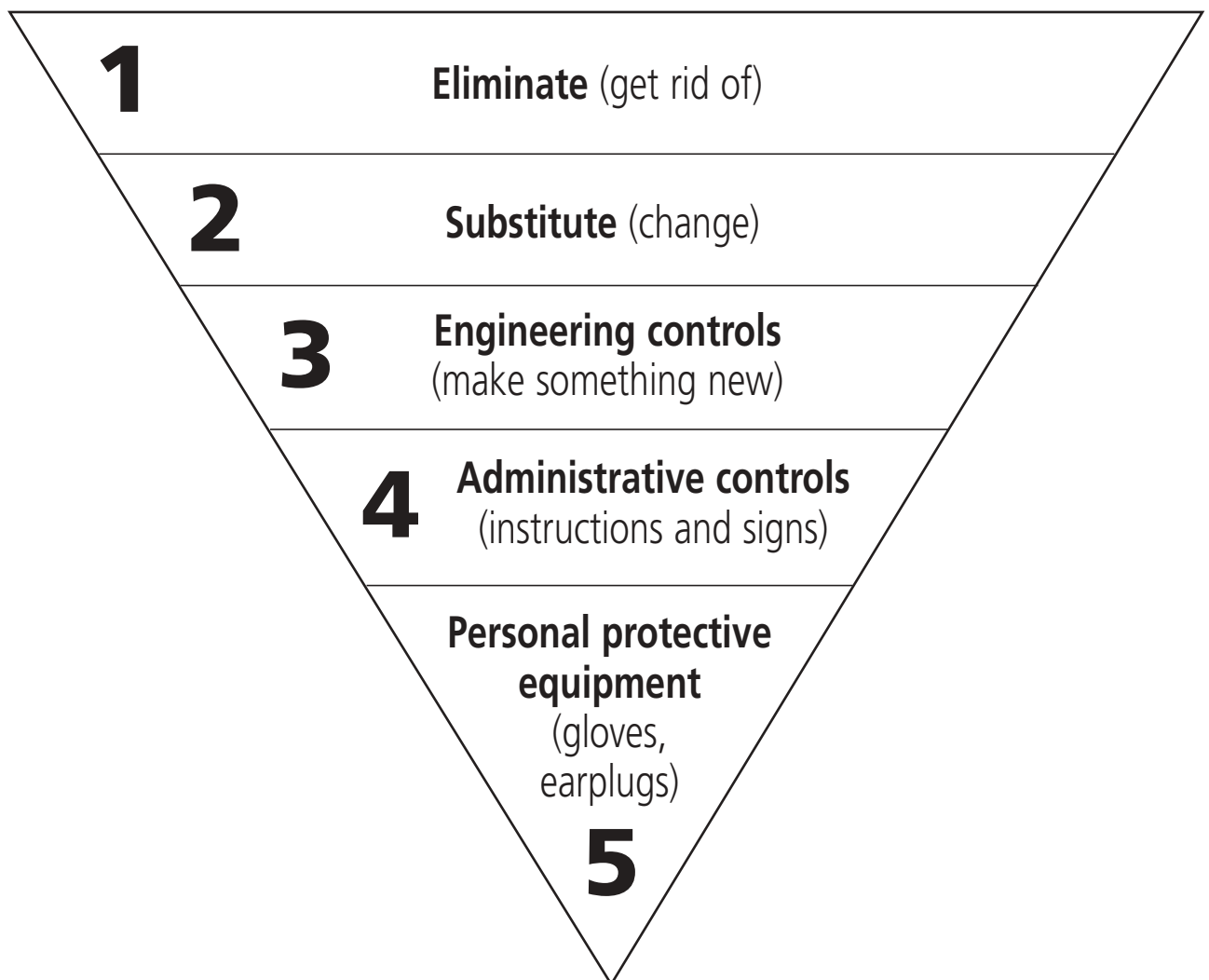

For example...

First you should try not to breathe in or touch the chemical



...but

If you cannot do this you need to wear your personal protective equipment.



What... do you have to do with your personal protective equipment?

1. Wear it when you need to.
2. Look after it and keep it clean.
3. Use it properly.

What... does your employer have to do?

1. Provide you with personal protective equipment.
2. Train you how to use it properly.
3. Replace equipment if broken.
4. Make sure it fits you.

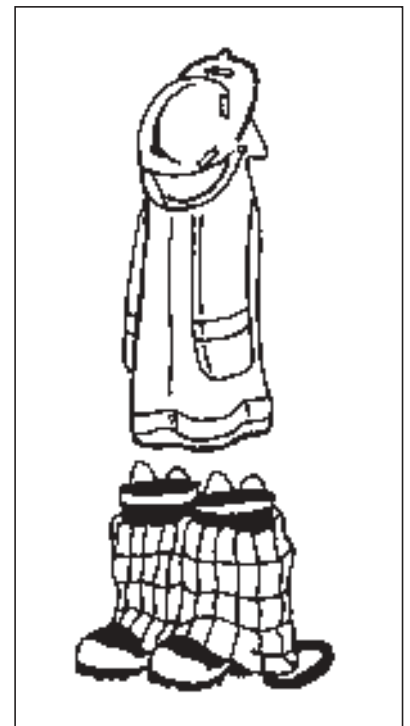

When... do you wear your personal protective equipment?

When... you feel unsafe.

When... told by your supervisor or team coordinator or your workmates.

When... your Material Safety Data Sheet tells you to.

When... a warning sign tells you.



face shields



gloves and boots

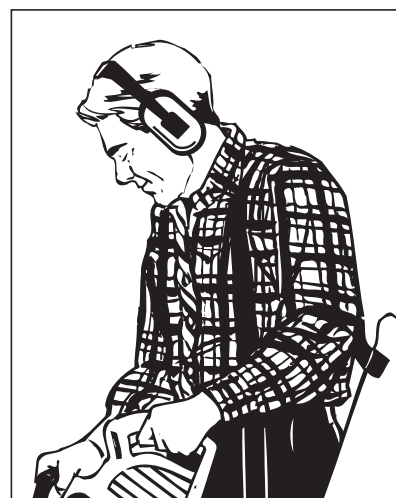

hearing protection

**If there is a
chance of injury**

**Wear your
personal protective equipment**

In these jobs... what personal protective equipment would you wear?

fireman



pest control
worker



welder



- | | | |
|-------------|------------------|---------|
| face shield | respiratory mask | glasses |
| earplugs | earmuffs | helmet |
| gloves | boots | goggles |
| | | apron |

Listening activity

John: "These safety glasses are so uncomfortable, they hurt me behind my ears. I didn't wear them before and I don't want to wear them now."

Van: "But you know that you need to wear them."

John: "No I don't. I've been working here over a year now and no-one's hurt their eyes yet."

Van: "Well, only two years ago, I was working at the lathe without my safety glasses and a piece of metal hit my eye."

John: "Oh, really."

Van: "Yes, I had to go to the hospital and have the metal removed. It took me two months to see properly out of that eye."

John: "That's terrible, I had no idea how important safety glasses were."

Van: "Yes, if only I'd worn my safety glasses none of this would have happened."

John: "OK, I guess it's important for me to wear my safety glasses. I'll just have to get used to them."

Van: "Onya John!"

Why doesn't John want to wear his safety glasses?

Why is it important for him to wear the safety glasses?

Have there been any eye injuries at your workplace? If so, describe an accident where someone injured their eye.

What personal protective equipment do you wear at your workplace?

Personal protective equipment... key words

English

First language

measure	_____	_____
properly	_____	_____
personal	_____	_____
protective	_____	_____
instruction	_____	_____
warning	_____	_____
chance	_____	_____
respiratory	_____	_____

Developing your writing skills

Write out the key words breaking them into syllables.

Example: m e a / s u r e (2)

properly _____ / _____ / _____

personal _____ / _____ / _____

protective _____ / _____ / _____

instruction _____ / _____ / _____

warning _____ / _____

chance _____

respiratory _____ / _____ / _____ / _____

Developing your writing skills

How many more words can you find that belong to the same word family?

Example: measure... (measured, measuring, measurement)

properly

personal

protective

instruction

warning

chance

Can you find the following words in the grid?

The first word has been done for you...

protective	mask	personal
gloves	earplugs	glasses
apron	respiratory	boots
measure	properly	

r	e	s	p	i	r	a	t	o	r	y	a	b	e
w	a	l	d	b	l	w	e	p	u	w	i	g	a
s	r	a	b	c	d	e	f	g	h	i	j	l	s
a	p	e	r	s	o	n	a	l	k	t	q	w	l
b	l	t	o	o	t	b	m	n	o	p	q	e	s
o	u	w	x	y	z	a	o	j	o	l	v	g	t
l	g	l	a	s	s	e	s	o	b	i	w	d	e
a	s	q	d	g	i	o	s	i	t	i	e	f	p
m	n	a	u	w	a	b	p	c	m	s	a	e	p
w	a	e	p	c	a	b	e	x	e	f	w	a	v
n	e	e	m	r	i	t	e	a	v	u	q	r	s
l	w	c	o	q	o	x	c	g	p	w	e	f	l
s	b	s	e	r	o	n	p	t	g	h	l	o	a
o	l	l	p	r	o	p	e	r	l	y	f	p	v
v	w	u	k	i	b	w	t	g	o	i	s	t	w
o	d	s	g	l	w	o	u	d	v	e	e	l	d
y	a	w	c	v	a	e	l	q	e	t	x	y	z
m	c	g	o	a	x	m	e	a	s	u	r	e	k

What is a confined space?

A confined space is an enclosed or partly enclosed space. Workers do not normally work there.

1. It may be hard to enter and exit.
2. It may have low oxygen levels or chemicals may be present.
3. It may not have normal air pressure.
4. It may cause a person to be crushed or suffocated.

Some examples are:

- a chemical storage tank
- a boiler pressure vessel
- a pipe
- a furnace

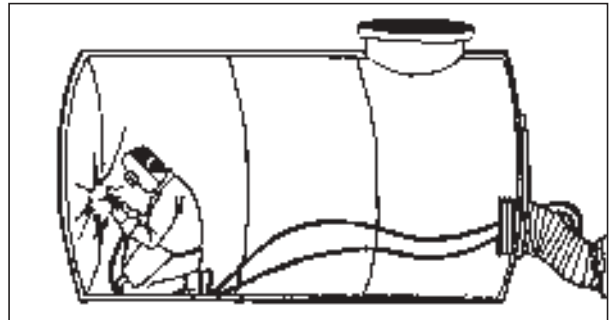

Can you think of any examples of confined spaces in your workplace?

What are the risks?

You could be...

harmed by chemicals in the air;

affected by low levels of oxygen;

harmed by flammable gases;

crushed or suffocated by grain, dirt or flour; or

trapped and it could be difficult to rescue you.

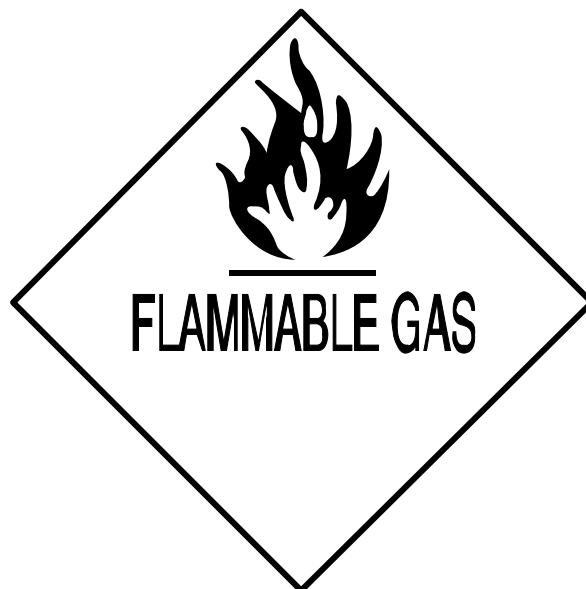

What are... your supervisor's or team coordinator's responsibilities?

1. Decide if you need to enter the confined space to do the job.
2. Know the risks in the confined space.
3. Know the emergency and rescue procedures.
4. Make sure there is someone watching you from outside.
5. Give you training in working in confined spaces.
6. Have a procedure for 'signing in' and 'signing out' of the confined space.

It is important for you to 'sign out' before the space can be used again.

For example:

A boiler cannot be used until you have 'signed out'.

If you are at risk in the confined space, there must be someone watching you from outside.

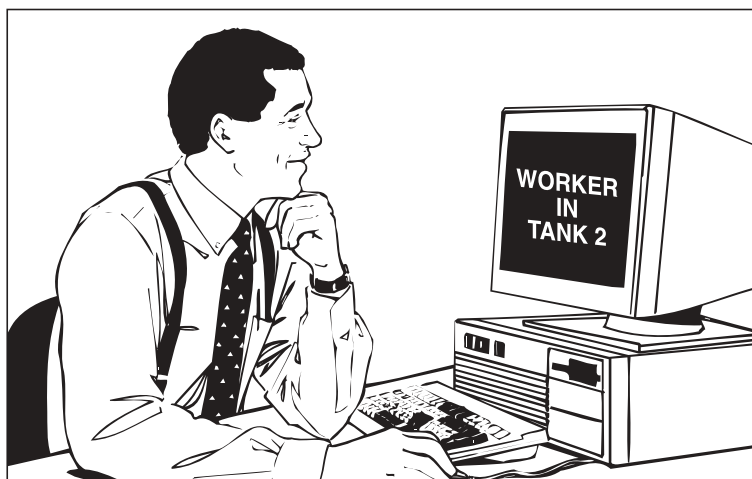

What must the worker do... before entering a confined space?

1. Check there is a safe level of oxygen.
2. Check there are not dangerous levels of chemicals in the air.
3. Check there are no flammable gases.
4. Check the temperature... it should not be too hot or too cold.
5. Be protected from germs.
6. Make sure all machines are turned off.

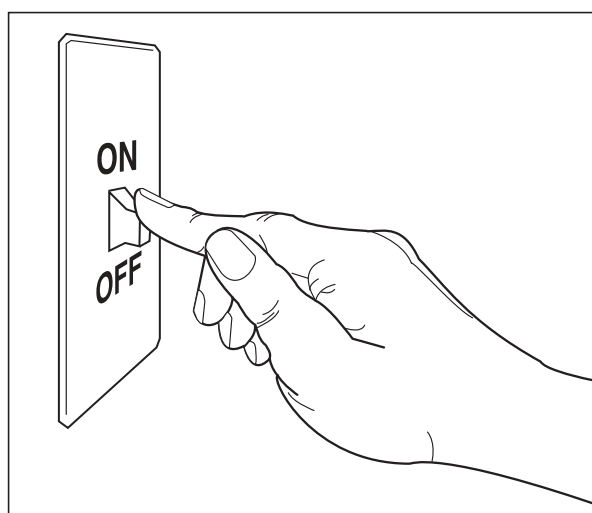

AND most importantly:

You must have been specially trained in working safely in a confined space.

You must wear your personal protective equipment.

Listening activity

Chris: "Van, if the supervisor's looking for me, I'll be in tank two repairing a weld line."

Van: "Have you got a buddy for the job?"

Chris: "No, actually I haven't. Do you want to give me a hand?"

Van: "Sure. Do I need to sign in?"

Chris: "Oh yeah, we have to do that first. Then we're ready to go."

Van: "Do we have to check the oxygen levels from the top to the bottom of the tank?"

Chris: "Oh yeah, that's very important. We need to make sure it's safe for me to go into the tank. We also have to check that there are no flammable liquids or gases left, otherwise, I'll be history."

Why should Chris and Van check the oxygen levels of the tank?

Why is it important that they make sure there are no flammable liquids or gases in the tank?

Van and Chris 'sign in' at the beginning of the job. What do they need to do when they have finished the job and why?

What does a 'buddy' do?

What does Chris mean when she says... "I'll be history!"

Working in confined spaces... key words

English

First language

enclose	_____	_____
enter	_____	_____
exit	_____	_____
crush	_____	_____
suffocate	_____	_____
risk	_____	_____
flammable	_____	_____

Developing your writing skills

Write out the key words breaking them into syllables.

Example: e n / c l o s e (2)

enter /

exit /

crush

suffocate / /

risk

flammable / /

Developing your writing skills

How many more words can you find that belong to the same word family?

Example: enclose... (enclosed, enclosing)

crush

suffocate

enter

flammable

risk

exit

Can you find the following words in the grid?

The first word has been done for you...

enclose	space	enter	exit
pipe	risk	flammable	confined
air	tank	oxygen	trapped
crushed	sign out	licence	suffocate

s	u	f	f	o	c	a	t	e	f
s	o	t	a	n	k	a	w	o	l
i	p	r	e	e	x	i	t	x	a
g	l	a	a	n	l	r	w	y	m
n	i	p	c	t	c	b	w	g	m
o	c	p	s	e	p	l	q	e	a
u	e	e	t	r	p	i	o	n	b
t	n	d	r	i	s	k	p	s	l
w	c	r	u	s	h	e	d	e	e
b	e	c	o	n	f	i	n	e	d

An emergency is...

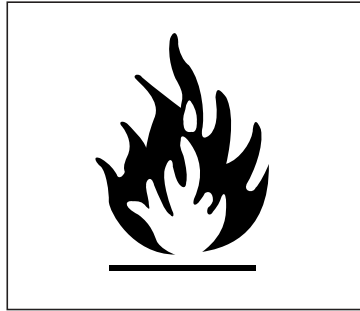

a fire

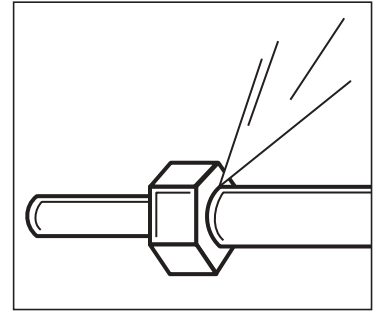

a gas leak

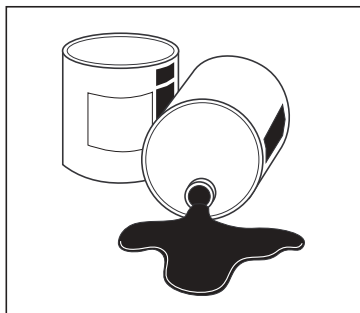

a chemical spill

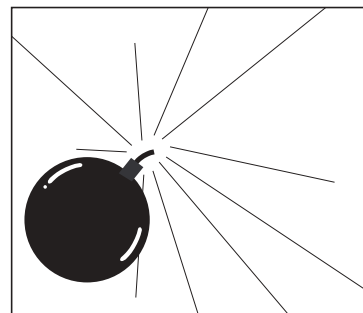

a bomb threat



a serious injury

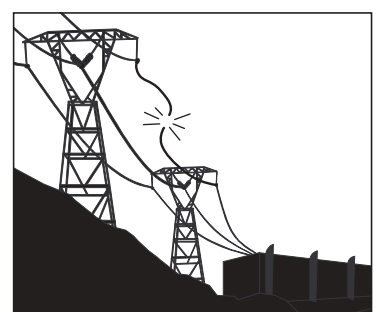

a power failure

What will you do in an emergency?

Cross out what you would not do:

go to the
bathroom

find a first
aid officer

tell your
fire
warden

ring home

go home

make sure
you clear out
your locker

warn other
workers in
danger

scream and
run out of
the building

tell your
supervisor
or
coordinator

ring the
emergency
number



What is first aid?

You need first aid if you hurt yourself:

1. if you... get a scratch;
2. if you... cut your finger;
3. if you... spill a chemical on your hands or in your eyes;
4. if you... burn yourself;
5. if... something gets in your eye; or
6. if you... sprain/strain a muscle like your ankle

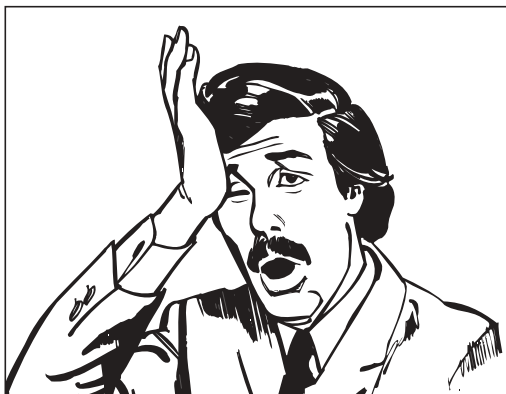

something gets in your eye



sprained/strained muscles



You need first aid... so that you can get help if you have an accident or feel sick.

What are the common injuries that happen and need first aid in your workplace?

You should have a first aid office and a first aid officer or health nurse at work. If you need first aid at work:

Who do you tell and where do you go to get help?

What if you're on night shift?

What do you do... if someone needs first aid immediately?

Stop the bleeding.
Apply pressure to the
wound and elevate.



Wash burns to skin under
cold running water.

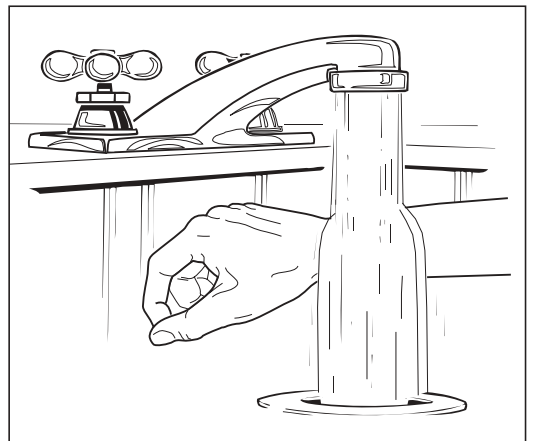

If someone has chest pain,
stay with them and get someone
else to get urgent medical help.



Don't just leave someone if there is an accident. Help them stay calm until the first aider arrives.

If a chemical is in someone's eye, help them to the eyewash basin.

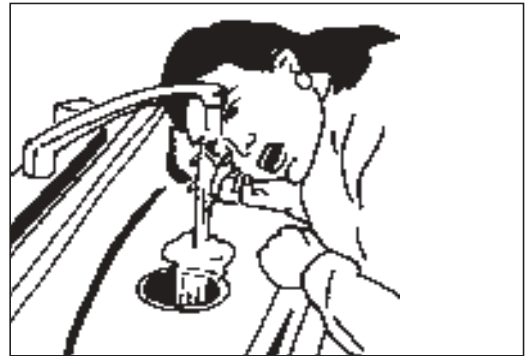

If a hard object like a piece of metal gets into someone's eye, stop them from rubbing it.

If someone has an electrical shock:

1. Check for danger.
2. Switch off the power.

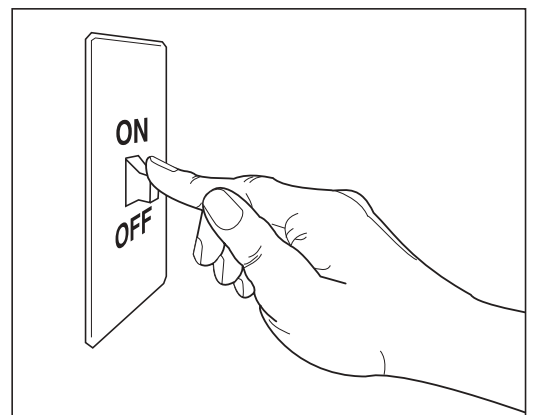

Do you have a first aid kit... at home or in your car?

Here are some items that you can find in a first aid kit:

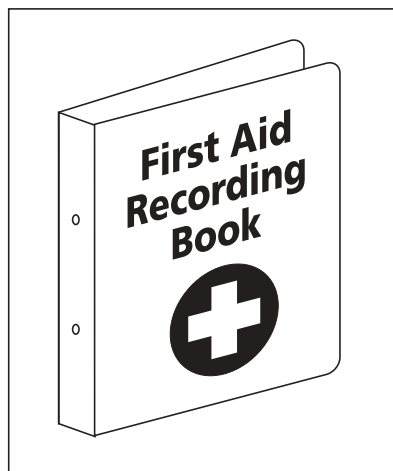

first aid
recording book

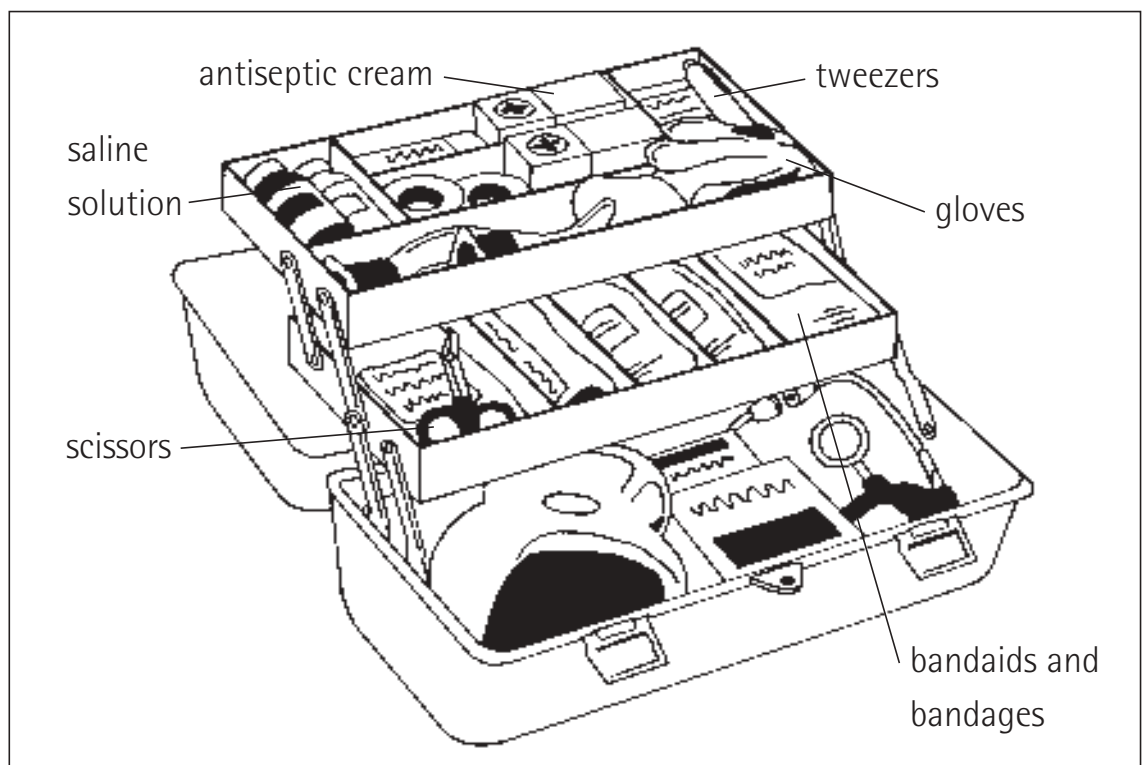

Fires... how do they start?

A fire will only start if you have all of these things together:
fuel, heat and oxygen.

fuel + heat + oxygen = fire

solvent + a spark + air = fire

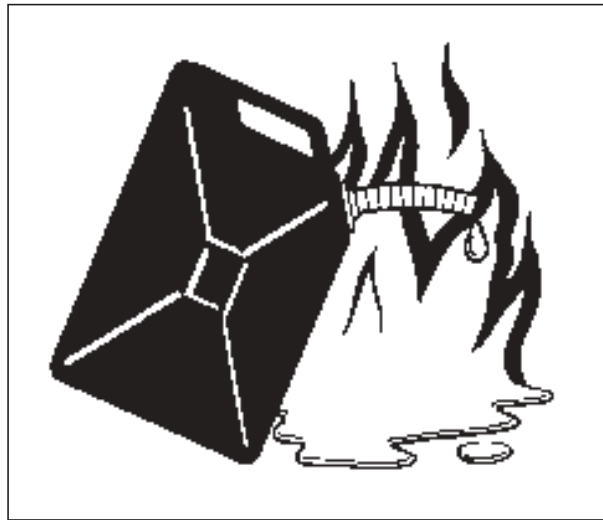

BE RESPONSIBLE!

Make sure that you don't start a fire. Always keep fuel, heat and oxygen separate

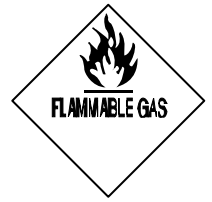

Fire prevention

Why do you have to always keep the lids on solvent tins and bottles?

Why do you need to keep your work area clear from rags, rubbish and paper?

Is it okay to leave solvents close to heaters?



Fire prevention

Why are chemicals and gases kept separate from each other?

What precautions should someone take before they start welding?

Where does dust build up in your workplace?

An evacuation happens because... there is a dangerous situation in the factory

What do you hear if you need to evacuate?

Evacuation steps...

1. Shut down your machine.
2. Go straight to your department assembly point.
Do NOT go to your locker.
3. Your warden will count everybody.
Do everything that the warden tells you to.
4. Walk, DO NOT RUN, to the section assembly point outside the building.
5. Your warden will count everybody again.
Stay at the assembly point until your warden tells you what to do.

**In an evacuation the warden
is the person in charge.
Do everything he/she tells you!**





Evacuation

Do you know what the evacuation procedure is in your workplace?

Do you know what happens when there is an evacuation?

What do you have to do if you are told to evacuate?

Listening activity

Jose is cleaning an oil drum with a solvent when...

Van: "Jose be careful! You're splashing the solvent all over yourself and your work area."

Jose: "Man, give me a break! I'll clean myself and the work area when I've finished."

Van: "But Chris is working just over there. She's using the oxy torch to cut those drums. Just one spark from that torch could ignite the solvent and start a fire."

Jose: "Well if it happens, I'll just use the fire extinguisher and put it out."

Van: "A fire can spread quickly. Do you really want to be the one warning all the other workers that they're in danger and having to ring the emergency number?"

Jose: "OK, you're right, Van. I do need to think of our safety first. It is important to prevent a fire from starting."

How can Jose prevent a fire from starting?

Why should solvents and heating equipment, like oxy-acetylene torches, be kept at a distance from each other?

If a fire began in your work area, what should you do?

Emergency procedures... key words

English

First language

emergency	_____	_____
procedure	_____	_____
evacuation	_____	_____
aid	_____	_____
sprain	_____	_____
pressure	_____	_____
elevate	_____	_____
solvent	_____	_____
prevention	_____	_____
precaution	_____	_____

Developing your writing skills

Write out the key words breaking them into syllables.

Example: e / m e r / g e n / c y (4)

procedure _____ / _____ / _____

evacuation _____ / _____ / _____ / _____ / _____

aid _____

sprain _____

pressure _____ / _____

elevate _____ / _____ / _____

solvent _____ / _____

prevention _____ / _____ / _____

precaution _____ / _____ / _____

Developing your writing skills

How many more words can you find that belong to the same word family?

Example: procedure... (proceed, procedural, proceeding)

evacuation

pressure

elevate

prevention

precaution

aid

Can you find the following words in the grid?

The first word has been done for you...

elevate	aid	procedure	pressure
danger	solvent	emergency	prevention
gas	scissors	fire	sprain
injury	heat	fuel	

e	a	p	i	n	j	u	r	y
l	m	r	g	a	s	s	p	t
e	g	e	p	g	o	p	m	n
v	p	v	r	s	l	r	d	o
a	o	e	o	g	v	a	a	u
t	l	n	c	p	e	i	n	e
e	w	t	e	s	n	n	d	s
m	a	i	d	b	t	a	c	k
l	x	o	u	o	n	i	r	y
i	c	n	r	g	s	f	m	p
f	p	r	e	s	s	u	r	e
r	i	r	o	w	l	e	h	g
t	n	r	b	l	p	l	s	q
o	s	h	e	a	t	b	j	u

All South Australian workers are covered for a work injury, illness or disease under the...

**Workers
Rehabilitation
and
Compensation Act,
1986**

If you are injured or become ill from your work duties then you have the right to workers compensation.

Some employers are what we call 'exempt'. This means that they manage their own claims. If your employer is not exempt a private insurance agent would be responsible for your claim. WorkCover Corporation makes sure that all workers have the same rights under the Act.

What do you have to do... if you need to make a claim?

1. Report the incident to your supervisor or team coordinator and the Health Centre as soon as possible. You should report any injury even if you do not need time off work.
2. Get the correct forms used at your workplace.
3. If you need medical treatment or time off work you need a prescribed medical certificate from your doctor.
4. You will be notified within ten working days if your claim is accepted.

Activity

Van was walking through the factory when he slipped down a step and hurt his leg. His workmates called the team coordinator over and he was taken to the hospital. X-rays showed he had a broken leg and would need six weeks off work. Van rang his team coordinator to tell him what the doctor had said. His team coordinator told Van he would need to fill in a *Notice of work-related injury* claim form.

Get a copy of the form used at your workplace and fill in the form for Van.

Van slipped down a
step and hurt his leg



Deciding your claim

If your claim is accepted you will be entitled to weekly compensation payments and any medical or travel expenses.

If your claim is **not** accepted you will be entitled to appeal and have your claim reviewed.

If you are off work for more than 12 months your weekly compensation payments will be reduced to 80 per cent of your original wage.

Rehabilitation

The emphasis of the Act is the rehabilitation of injured workers and their return to productive work.

There is a **legal obligation** for employers to offer a person alternative or light duties. You cannot be sacked just because you have an injury.

- a) If you need time off work or a different job then you will need a return-to-work plan.
- b) The aim of a return-to-work plan is to return the injured worker to the work they did before the injury as quickly and as safely as possible.

The employer, the worker and their doctor need to cooperate with each other to make sure they plan a safe return to work.



planning a safe return to work

Do you know your responsibilities?

If you suffer an injury at work you must:

Report the injury to your team coordinator immediately.

Attend proper treatment for your injury.

Provide a prescribed medical certificate from your doctor when time is lost from work.

Participate actively in the planning and implementation of a rehabilitation program.

Return to work within your capacity and in a timely manner.

Perform suitable duties for which you are fit.

Submit to a medical examination when asked to do so.

Do you know your rights?

If you are injured at work you are entitled to:

lodge a claim for compensation;

choose your own doctor;

have any personal information concerning you kept confidential by anyone involved; and

have a representative present at any meeting to discuss your claim or rehabilitation.

If you are involved in a rehabilitation program you are also entitled to:

have a current copy of your rehabilitation program;

participate in all decisions regarding your rehabilitation program; and

be provided with a complete copy of the employer's rehabilitation policy.

Activity...

Get a copy of the rehabilitation policy for your workplace.

Discuss what your employer would do for you if you were injured at work.

What would your employer do for you if you were injured at work?

Listening activity

Miroslav rubbed his aching shoulder as he took off his gloves for smoko break. The cold weather seemed to make it worse so he thought he'd call into the Health Centre - a massage would probably fix it.

Miroslav: "Hi, I've got a pain in my shoulder. Would you mind giving me a massage - ah, if you've got time?"

Jeanne: "How long have you had this pain Miroslav?"

Miroslav: "Oh, maybe two months now."

Jeanne: "Why didn't you come earlier? The sooner you report an injury the easier and quicker it is to treat."

Miroslav: "Oh, I thought it would go away and I didn't want to make a fuss."

Jeanne: "Miroslav, it's not a fuss, that's why I'm here. Look, first we'd better fill in the incident report and I'll go and assess your job. I'd also like you to see the occupational physician - two months is quite a while. You'll also need to see Kaye about the rehabilitation process and about possible selected duties."

Miroslav's thoughts started to drift. Poor Van and John. How were they going to cope with production? Would the others think he was being lazy?

When should Miroslav have told someone about his shoulder?

Is reporting aches and pains making a fuss?

What will probably happen to Miroslav at work?

Claims management and rehabilitation... key words

English

First language

compensation	_____	_____
rehabilitation	_____	_____
insurance	_____	_____
exempt	_____	_____
treatment	_____	_____
incident	_____	_____
entitled	_____	_____
obligation	_____	_____
confidential	_____	_____
implementation	_____	_____

Developing your writing skills

Write out the words breaking them into syllables.

Example: c o m / p e n / s a / t i o n (4)

rehabilitation _____ / _____ / _____ / _____ / _____ / _____

insurance _____ / _____ / _____

exempt _____ / _____

treatment _____ / _____

incident _____ / _____ / _____

entitled _____ / _____ / _____

obligation _____ / _____ / _____ / _____

confidential _____ / _____ / _____ / _____

implementation _____ / _____ / _____ / _____ / _____

Developing your writing skills

How many more words can you find that belong to the same word family?

Example: compensation... (compensate, compensated)

rehabilitation

insurance

exempt

entitled

obligation

confidential

Writing activity

Words in English often have a **prefix** or a **suffix**.

A *prefix* goes in front of a word...

For example: happy... unhappy

A *suffix* goes at the end of a word...

For example: happy... happiness

'tion' is a common suffix in English...

Words that end in "tion" are nouns.

Which words in your key word list end in the suffix... 'tion'?

_____	_____
_____	_____
_____	_____

Can you think of five more words that end in 'tion'?

_____	_____
_____	_____
_____	_____

Does someone do any of these things to YOU or other workers in YOUR workplace?

- continuously threaten you
- constantly look over your shoulder while you do your work
- call you names, tease, insult or generally make fun of you
- always tell you that you are not doing a good job
- make you feel kept apart and keep you away from the group
- make you feel afraid and worried
- deliberately not include you in workplace activities
- spread gossip about you
- give you an unreasonable amount of work to do
- hide your tools or belongings

If you ticked yes to any of these things then workplace bullying might be a problem in your workplace.

What is workplace bullying or harassment?

It is continuous bad treatment of someone at work by someone else.

Workplace bullying and harassment can continue unchecked because people often don't want to talk about it. Some people think it is just a part of the workplace environment but it can be very harmful to a person's health and wellbeing.

Workplace bullies come in all shapes and sizes. They can be men or women and they can be managers, supervisors or other workers. Bullies can harass one person or a group of people.

Are there laws to protect you from bullies in the workplace?

YES



The Occupational Health, Safety and Welfare Act (1986) says that it is the responsibility of an employer to provide a safe workplace for all employees. No worker should be at risk in the workplace.

If a worker's health and well being is affected, or they become ill, stressed or are away from work because of bullying, then there are laws to help stop the problem.

If the bullying involves physical harm or the threat of a physical attack, then there are criminal laws to help protect workers.

Sometimes people get bullied because they are different. If someone is bullied on the basis of their sex, race or ethnic background, disability, sexual preference, marital status, pregnancy or age, then they are protected by the Equal Opportunity Act (1984).

What happens in a workplace where there is bullying and harassment?

- The workplace is less productive and efficient.
- People feel afraid and insecure.
- There are high levels of stress and conflict among workers.
- Employers have higher costs.

What happens to someone who is being bullied?

When someone is being bullied they can suffer from a number of stress-related illnesses that affect them not only at work but at home in their family relationships and in their social and community life.

At work



Being bullied can make someone:

- get headaches, nausea, depression, not sleep and always be tired
- lose confidence about themselves and what they can do
- not want to be with other people at work or outside work
- not do their job properly because they lose their concentration and they are worried
- not go to work, take sick days or regularly be late for work
- have an increased risk of a work-related injury
- feel anxious and sometimes have panic attacks
- resign from their job

At home

Being bullied can make someone:

- not want to do many things
- worry about the next time they have to go to work and what might happen to them
- become physically ill, suffer from depression and not want to be with anyone
- increase their use and abuse of alcohol or drugs
- get very upset about things that don't matter much
- need continued understanding and support
- tend to blame others for their problems

Family, children and friends can suffer the most from the effect of workplace bullying.



The effects of workplace bullying can be hidden. The bullies themselves may tend to deny there is a problem at all. The people who are being bullied tend to lose their sense of self worth which means they can find it hard to complain or stand up for their rights. Some people who are bullied even blame themselves.

Workplace activity

Have you ever been a victim of a workplace bully?

Or perhaps when you were at school?

How did you feel? What did you do?

Discuss your responses in your group.

What is the effect of bullying on other workers?

Other workers who can see what is happening might:

- feel guilty because they know that it's wrong but they don't feel able to do anything about it or don't want to get involved
- be afraid to give any support or help to the person who is being bullied in case it starts to happen to them too
- feel angry and unhappy at work.

What is the effect of bullying on the overall organisation?

- More mistakes can be made by tired workers who cannot concentrate because of a negative work environment.
- There is an increase in workers compensation claims both directly (eg stress-related claims) and indirectly (eg injuries resulting from tiredness and poor concentration).
- Highly trained and experienced workers resign and leave their jobs.
- Teamwork suffers because there is less cooperation and communication.
- There is an increase in the use of alcohol or drug abuse at work.
- There is very little respect for the employer and the company when nothing is done to stop this sort of behaviour.

What makes someone become a workplace bully?

There can be a number of reasons such as:

- they might believe that bullying is the only way to effectively manage workers
- they might not be aware of the effect of what they are doing or even that they are being a bully
- they might have a drug or alcohol abuse problem
- they might be afraid of becoming the next person who is bullied.

If you or another worker are being bullied at work ... you must tell somebody

Supervisor/team coordinator

Safety representative

Employer /manager

Many cases of bullying are not reported for many reasons. Sometimes people are afraid to report bullying yet bullies can rely on the very silence of their victims to keep on harassing them.

Remember ... workplace bullying is against the law

No matter who is doing the bullying it is the employer's responsibility to stop it.

The occupational health, safety and welfare law and regulations say that employers must provide a safe and healthy working environment.

Workplace activity

Think about the people in your workplace.

Write down the names of the people who you would go and talk to if you, or someone else, was being continuously bullied or harassed at work.

An employee's step-by-step guide to dealing with workplace bullying

(1) Recognise the signs

- Are you being intimidated, threatened or isolated?
- Is your work performance always being picked on unfairly or unreasonably?
- Are you being humiliated in front of other workers?
- Are you being threatened with dismissal?
- Are these incidents continuous and persistent?

(2) Do not worry about why it is happening

- It is against the law to continuously bully and harass a worker

(3) Clearly identify the bully or bullies

- Make sure you know exactly who is doing the bullying.
- Is there a ringleader?
- Who has the power?

(4) Keep records

- Keep a diary or notes of bullying incidents, when and where it happened, who was responsible, how you felt, potential witnesses etc.
- Notes are important to demonstrate a pattern of events.
- It is important to have records if you are making claims for compensation.

(5) Talk about it

- Discuss the problem with other workers, health and safety representatives and union officials.

(6) Do not retaliate

- Do not become a bully yourself or use physical violence or you may be seen to be no better than the bullies themselves.

(7) Stay where you are

- Do not resign or seek a transfer, as this would be letting the bully win.
- You need to address the problem with your network of support in your work environment.

(8) Make a formal complaint

- If you are making a formal complaint it needs to be in writing (always keep a copy).
- Make sure your formal complaint shows a consistent pattern of mistreatment and that you use the correct procedure (get help if you are not sure).

(9) If your management doesn't help you

There are other organisations which can help you such as:

- The Equal Opportunity Commission
- The Office of the Employee Ombudsman
- The Working Women's Centre
- Workplace Services
- WorkCover Corporation

A manager's step-by-step guide to dealing with workplace bullying

- (1) Clearly state the organisation's intolerance of workplace bullying
- (2) Establish policies and procedures and provide training in their implementation to prevent workplace bullying
- (3) Appoint a workplace bullying officer
- (4) Make it a regular agenda item on the OHS Committee meetings
- (5) Listen carefully to what is occurring in the workplace
- (6) Investigate all complaints of workplace bullying
- (7) Act immediately and firmly
- (8) Keep records
- (9) Get some training and assistance
- (10) Monitor the workplace for indications of workplace bullying and identify the reasons for bullying

Workplace activity ... a case study

In small groups read the following workplace case study out aloud. Then discuss your answers to the questions together.

Francesca was the Office Manager for a meat processing company.

Three people, a husband and wife and their brother-in-law owned the company.

One of the owners constantly told Francesca that she was not doing a good job. He would pick on her work and tell her that if she wasn't careful she would get the sack. He used to swear at her and tell her to do her job the way he wanted which was different from the way the other two owners wanted the work done. He would often say: "I'm the owner and I can do what I like. I can fire you whenever I want to!"

Francesca was always worrying about her job. At work she felt very nervous, couldn't concentrate and sometimes made mistakes or forgot to do things.

Nobody else in the company ever complained about her work which she had been doing for some time now.

Francesca was very unhappy and confused yet she didn't know why all of this was happening. This owner was always looking over her shoulder while she worked and he would listen in to her telephone conversations. This would make her so nervous and uncomfortable that she would end up making more mistakes.

At home Francesca didn't spend as much time with her family and friends any more. She got lots of headaches and got upset about things that didn't really matter. She wasn't sleeping as well so she was always tired. Her family was worried about her.

Each day Francesca would worry about what this owner might say or do next. Whenever she talked on the phone to other companies she was not as friendly any more. She wondered if they had complained about her. Francesca's self confidence was very low.

She didn't know what to do because the person bullying her was one of the owners and they were all related. She didn't know if she should tell the other owners or not and she was afraid of losing her job.

Even when she was sick and took a day off work he would make fun of her and suggest that she had not really been ill at all. He would continuously threaten her with the sack if she did not improve her work.

What was happening to Francesca at work?

What could Francesca do about it?

Who could Francesca talk to about what was happening?

What was happening to Francesca at home?

What would you do if you were Francesca?

Acknowledgement : This material has been adapted from the following publications;

References: SA Office of the Employee Ombudsman "Bullies Not Wanted", 1999
SA Working Women's Centre "Workplace Bullying Project", 1997

Workplace bullying and harassment ... key words

English

First language

bullying	_____	_____
harassment	_____	_____
unreasonable	_____	_____
wellbeing	_____	_____
insecure	_____	_____
stress	_____	_____
intimidate	_____	_____
retaliate	_____	_____
concentration	_____	_____
depression	_____	_____
humiliated	_____	_____
isolated	_____	_____

Developing your writing skills

Write out the key words breaking them into syllables.

Example: w o r k / p l a c e (2)

bullying _ _ _ _ / _ _ / _ _ _ _

harassment _ _ _ _ / _ _ _ _ / _ _ _ _

unreasonable _ _ _ / _ _ _ _ _ / _ _ _ / _ _ / _ _ _ _

wellbeing _ _ _ _ _ / _ _ _ / _ _ _ _

insecure _ _ _ / _ _ _ _ / _ _ _ _

stress _ _ _ _ _

intimidate _ _ _ / _ _ _ _ / _ _ / _ _ _ _ _

retaliate _ _ _ / _ _ _ _ / _ _ / _ _ _ _

concentration _ _ _ _ / _ _ _ _ _ / _ _ _ / _ _ _ _ _

depression _ _ _ / _ _ _ _ _ / _ _ _ _

humiliated _ _ _ _ / _ _ _ / _ _ / _ _ _ / _ _ _

isolated _ _ / _ _ _ / _ _ _ _ / _ _ _

Developing your writing skills

How many words can you find that belong to the same word family?

Example: workplace... (worker, working, unworkable)

stress

unreasonable

intimidate

concentration

depression

harassment

Can you find the following words in the grid?

The first word has been done for you...

harassment	bully	gossip	health
people	worker	supervisor	legal
welfare	hidden	depress	suffer
related	direct	safety	grievance

h	a	r	a	s	s	m	e	n	t	k	m	y	p	l	s	s	r	h	b
e	p	r	e	f	f	u	s	u	d	i	r	e	c	t	s	s	t	u	k
a	f	q	e	w	a	a	p	p	b	b	o	o	y	h	g	w	l	e	v
l	p	c	d	b	q	f	l	e	g	a	l	f	y	h	g	l	k	e	n
t	a	y	j	a	z	v	f	o	r	v	b	h	l	w	y	l	p	t	e
h	i	d	d	e	n	x	g	p	i	v	i	e	g	o	s	s	i	p	i
s	d	f	e	h	j	k	b	l	d	f	i	x	x	r	r	y	f	h	y
x	c	v	p	t	t	q	w	e	e	r	h	s	l	k	z	x	c	v	b
e	w	q	r	e	l	a	t	e	d	a	s	d	o	e	f	g	h	j	k
r	t	y	e	u	u	i	o	p	w	e	l	f	a	r	e	b	n	m	l
a	z	x	s	a	f	e	t	y	c	v	g	r	i	e	v	a	n	c	e
q	w	e	s	r	t	y	u	i	o	p	a	s	d	f	g	h	j	k	l

Review

Now that you have almost finished your Workplace Health and Safety training it's time to reflect on what you have learned.

Please take the time to fill in the sheets on the next pages. Then your trainer can compare what you know now to what you knew before the course.

We hope that you enjoyed the training package and that you continue to learn new skills.

Post-evaluation

Name: _____

Organisation: _____

Date: _____

Gender: Male Female

Country of birth: _____

Years at school: _____

Please circle a number to answer the following questions.

How much do you now know about safety?

The safety laws

1	2	3	4	5
not very much		adequate		a lot

Health and hygiene

1	2	3	4	5
not very much		adequate		a lot

Recognising safety hazards

1	2	3	4	5
not very much		adequate		a lot

Manual handling

1	2	3	4	5
not very much		adequate		a lot

Hazardous substances

1	2	3	4	5
not very much		adequate		a lot

Noise problems in the workplace

1	2	3	4	5
not very much		adequate		a lot

Machine and equipment safety

1	2	3	4	5
not very much		adequate		a lot

Personal protective equipment

1	2	3	4	5
not very much		adequate		a lot

Working in confined spaces

1	2	3	4	5
not very much		adequate		a lot

Emergency procedures

1	2	3	4	5
not very much		adequate		a lot

Claims management and rehabilitation

1	2	3	4	5
not very much		adequate		a lot

Workplace bullying and harassment

1	2	3	4	5
not very much		adequate		a lot

How would you rate your English skills?

Speaking

1	2	3	4	5
very poor		average		very good

Listening

1	2	3	4	5
very poor		average		very good

Reading

1	2	3	4	5
very poor		average		very good

Writing

1	2	3	4	5
very poor		average		very good

Do you feel more confident about your understanding of safety at work?

Please tick the appropriate box Yes No Not sure

Do you feel more confident about your English skills?

Please tick the appropriate box Yes No Not sure

Do you have any further comments about this course?

Thank you.